



PHOENICS – Your Gateway to CFD Success

Documentation for PHOENICS | TR 006

What's New in PHOENICS:

Updates and Additions:

CHAM Ref: CHAM/TR006

Document rev: 21

Doc. release date: 4 June 2024

Software version: PHOENICS Classic 2023 SP (v1.1)

Responsible author: J C Ludwig

Other contributors: M R Malin

Editor: J C Ludwig

Published by: CHAM

Confidentiality:

Classification: Unclassified

The copyright covers the exclusive rights to reproduction and distribution including reprints, photographic reproductions, microform or any other reproductions of similar nature, and translations. No part of this publication may be reproduced, stored in a retrieval system or transmitted in any form or by any means, electronic, electrostatic, magnetic tape, mechanical, photocopying, recording or otherwise, without permission in writing from the copyright holder.

©Copyright Concentration, Heat and Momentum Limited 2024

CHAM, Bakery House, 40 High Street, Wimbledon, London SW19 5AU, UK

Telephone: 020 8947 7651 Fax: 020 8879 3497

E-mail: phoenics@cham.co.uk, Web site: <https://www.cham.co.uk>



What's New in PHOENICS

Contents

Items in PHOENICS 2023 Classic SP (v1.1). (May 2024)	4
Corrections to VR-Editor	4
Corrections to VR-Viewer	4
Corrections to Earth Solver	4
New Item in Earth Solver	5
Items in PHOENICS 2023 v1.0. (December 2023)	6
VR-Editor	6
Pasquill stability criteria in the WIND object	6
Ergun and porous material pressure drop for fluid-material BLOCKAGE	7
Thermal Capacity for Surface Heat Balance at non-participating BLOCKAGE	8
VR-Viewer	8
Logarithmic Contour Plots	8
Surface Contour Improvement	10
Display of VTK results	11
Solver – Earth	12
Steady State VOF	12
Improvements to convergence monitor	13
Disable File Numbering for Intermediate Dumps	13
USP extension	14
Corrections	15
VR-Editor	15
VR-Viewer	15
Earth - Solver	15
Items in PHOENICS 2022 v1.0.2 (December 2022)	17
Solver – Earth	17
VR Editor and Viewer	17
Flair	17
Items in PHOENICS 2022 v1.0 (September 2022)	18
Solver - Earth	18
Flair / Flair-EFS	22
VR Editor	23
Corrections	24
Items in PHOENICS 2021 v1.0 (August 2021)	25
Graphics Update – Common to Editor and Viewer	25
VR-Editor	27
VR-Viewer	31
Solver - Earth	35
Flair	36

For information about even earlier versions of PHOENICS, see 'The PHOENICS Chronicle', available online at https://www.cham.co.uk/phoenics/d_polis/d_chron/chron.htm

Items in PHOENICS 2023 Classic SP (v1.1). (May 2024)

The May 2024 release of PHOENICS 2023 Classic SP (v1.1) is primarily a 'service pack' release to correct some defects found in the original PHOENICS 2023 release in December 2023.

Corrections to VR-Editor

- When setting a heat or scalar source on the outer surface of a 198 object, the flag for setting a total source for the object, or a source per-unit area was sent to the Earth solver the wrong way round – i.e. a source flagged as 'total' was interpreted by Earth as 'per-unit-area' and vice-versa. This is fixed.
- When the automesh control parameters were reset to default, the maximum size ratio was not reset. This is now fixed.
- When the output from a POINT_HISTORY object was limited by sweep or step, the limitation was sometimes not formed correctly and was ignored. This is now fixed.
- The 'propagate changes' button which appears when the object dialog is closed for a group of objects, any InForm commands added were not propagated to the other selected objects. This is now fixed.
- Sometimes very small numbers can appear due to round-off – e.g. values of the order 10^{-17} . This could cause problems with detecting if objects were on the domain boundary or not. These miniscule values are now automatically reset to 0.0.

Corrections to VR-Viewer

- The line plot window is redrawn fully after resizing the display window. This ensures the image quality is not destroyed by repeated window size changes.
- The line plot window must be closed before a macro can be run, or before the solution file (phida) can be changed.
- Corrections to the treatment of non-zero domain origin by the line plot and probe.
- For MOFOR, moving objects with the initial position 'at_start' or 'at_end' would not move during an animation. This is now fixed.

Corrections to Earth Solver

- If a COVAL command embedded in an InForm line does not have two arguments, an error message is issued and the run stops. Previously the run would continue but the applied source would be wrong.
- A single line of InForm is allowed to contain several PWLF or INTPOL commands. Previously this would work in serial mode, but fail in parallel.
- The file to be used by PWL or INTPOL can be specified as a local file (in the current working directory) or by its full path. Relative path names (e.g. `..\..\myfolder\myfile.txt`) are not allowed. Previously only local file names were allowed.
- The calculation of the automatic time-step for transient cases did not produce the expected time-step for parallel cases. This is fixed.
- Some parallel cases fail with 'Problem with geometry detection - insufficient grid?'. The cause of this has been traced and fixed.
- When a heat or scalar source is applied to the outer surface of a 198 blockage, and the source is set as 'Total', the source was applied over the total area of the object, including areas not exposed to the fluid, either by being outside the domain or by being covered by another solid. The whole of the source is now only applied to the parts exposed to fluid.
- Correction to surface-area calculation at ANGLED_IN object for Sparsol.
- Unprotected debug WRITE statement removed from VOF in steady mode.

New Item in Earth Solver

The use of *RAD as the first 4 characters of a PATCH name for the TEM1 variable has for many years allowed a radiative source to be created, of the form $Q'' = CO*((VAL+TEMPO)^4 - (TEM1cell+TEMPO)^4)$. E.g. PATCH(*RAD1,HIGH,1,NX,1,NY,NZ,NZ,1,LSTEP); COVAL(RAD1,TEM1, emissivity* σ , Tsurr).

This is good as long as the Coefficient and VALue remain constant. It is now possible to use the same 'trick' in InForm. E.g. to make the surrounding temperature Tsurr vary with time we can use:

(SOURCE of T3 at RAD1 is COVAL(emissivity* σ , PWLF(tsurr.csv,TIM))

Where tsurr.csv is a file containing the time-variation of the external temperature. Any valid formula can be used for the Coefficient and / or VALue of the InForm COVAL.

Items in PHOENICS 2023 v1.0. (December 2023)

VR-Editor

Pasquill stability criteria in the WIND object

The Wind Object has been upgraded to include Pasquill Stability conditions, thus allowing external wind calculations with stratified boundary layers to be performed. This applies to density-differences due to temperature or concentration changes – as in a release of dense gas.

For Power-law and tabular velocity profiles, the inlet temperature profile is assumed constant. For the default logarithmic velocity profile, the temperature profile can be obtained using one of the Pasquill stability classes and a Monin-Obukhov length.

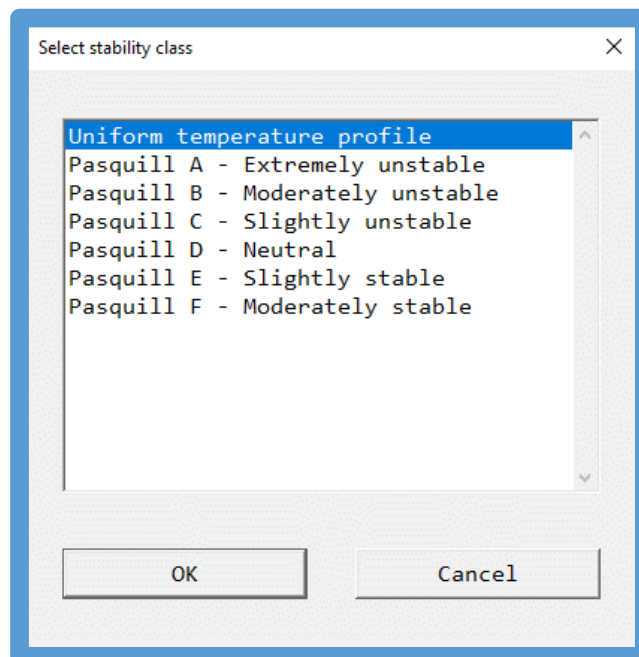

If one of the Pasquill classes is selected, another line appears on the dialog for the Monin-Obukhov length:

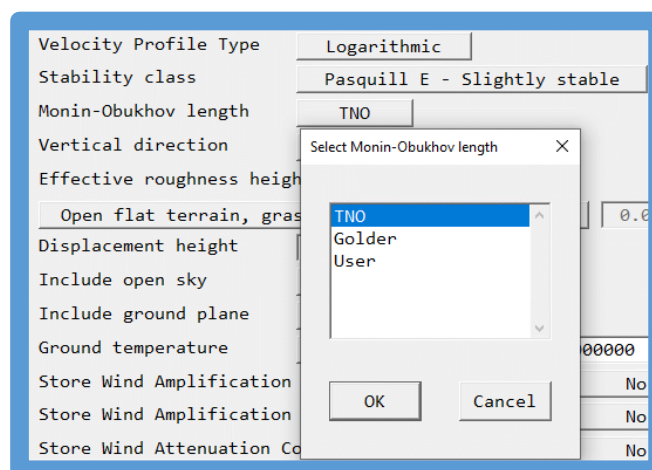

Please see https://www.cham.co.uk/phoenics/d_polis/d_enc/pasquill.pdf for further explanation.

Ergun and porous material pressure drop for fluid-material BLOCKAGE

For BLOCKAGE objects with fluid properties, additional pressure-drop formulations have been added:

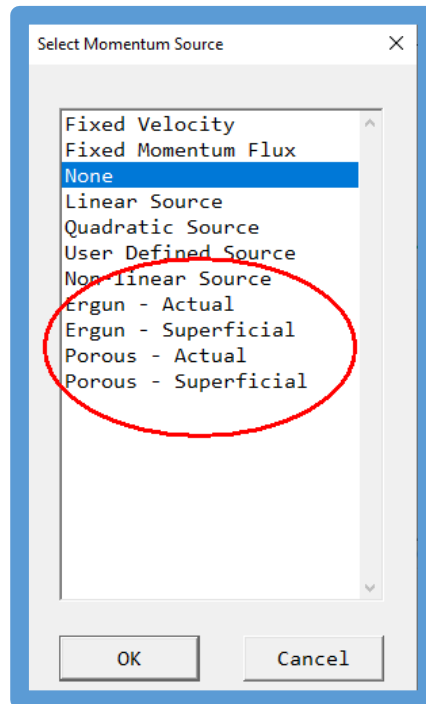

Ergun - Actual / Ergun -Superficial: The force applied is calculated from the Ergun equation for pressure-loss in a packed bed.

The force is

$$F = \text{mass-in-cell} * (150 * \nu * (1-P)^2 / (P^3 * D_p^2) * (V - \text{Vel}_p) + 1.75 * (1-P) / (D_p * P^3) * V_{\text{abs}} * (V - \text{Vel}_p))$$

where:

- ν is laminar kinematic viscosity,
- P is gas porosity (1=open, 0 = blocked)
- D_p is the particle diameter
- V_{abs} is the local absolute velocity
- V is the velocity of the packed bed
- Vel_p is the local velocity in X (U1), Y (V1) or Z (W1)

For 'Actual', the porosity value is applied to the cell face areas, so the velocity is the actual device velocity. For 'Superficial', the face areas are not adjusted, and the velocity is the approach velocity. The form of the source is modified to account for this. The expression above is the 'Superficial' form.

In RESULT, the source from the linear part is reported as the source from patches with names OV, and the quadratic part as sources from patches OW.

Porous - Actual / Porous -Superficial: The force applied is calculated from an equation for pressure-loss through a porous medium allowing for viscous (linear) and inertial (quadratic) contributions.

The force is

$$F = \text{Volume-of-cell} * (1-P) * (\text{ConstA} * \text{Vel} + \text{ConstB} * \text{Vel} * V_{\text{abs}})$$

where:

- P is the gas porosity (1=open, 0 = blocked)
- ConstA is the constant for the linear part
- ConstB is the constant for the quadratic part

- Vel is the local velocity in X (U1), Y (V1) or Z (W1)
- Vabs is the local absolute velocity

For 'Actual', the porosity value is applied to the cell face areas, so the velocity is the actual device velocity. For 'Superficial', the face areas are not adjusted, and the velocity is the approach velocity. The form of the source is modified to account for this. The expression above is the 'Superficial' form.

Thermal Capacity for Surface Heat Balance at non-participating BLOCKAGE

For a non-participating solid, when the energy source is set to 'Surface Heat Balance', the surface temperature is deduced from a heat balance between the fluid temperature in the cell adjacent to the surface, and a user-set fictitious internal temperature. The heat flux is then computed based on the surface temperature and an external heat transfer coefficient obtained from the wall function, or as a user-set constant.

From this release, in transient cases, the thermal capacity of the solid is estimated from a nominal material and thickness. This is then added to the heat balance for the surface temperature:

$$T_{surf} = (R_t * R_i * T_p + R_t * R_f * T_{solid} + R_i * R_f * T_{surfO}) / (R_t * R_i + R_t * R_f + R_i * R_f)$$

where R_i is a user-set internal resistance, R_f is the fluid-side resistance (i.e. 1/heat transfer coefficient), T_p is the cell temperature, T_{solid} is the (constant) user-set internal value and

$$R_t = Dt / (\rho * Cp * \delta),$$

where Dt is the time step, ρ is a nominal density, Cp a nominal specific heat, δ a nominal thickness and T_{surfO} the surface temperature at the previous time step. The properties are taken from the selected nominal material:

The screenshot shows a dialog box with the following fields and values:

- Energy Source: Surface heat balance
- Link Coeff: 0.010000 W/m/°C
- Internal Value: 20.00000 °C
- Material: 102 BRICK at 20 deg c
- Thickness: 0.500000 m

The 'Link Coeff' in the above dialog is the reciprocal of the internal resistance R_i .

Note that for cases using the SUN object for solar heating, and / or the IMMERSOL model for radiation, the solar heat load and radiative contributions are both included in the heat balance equation which becomes iterative.

VR-Viewer

Logarithmic Contour Plots

Traditionally, the contour plots produced by the VR-Viewer have always used linear scales. In the majority of cases this is exactly what is needed. However, there are occasions when the linear scale hides too much detail, especially when the range of contour values spans several orders of magnitude. A typical situation might be smoke spread in a fire.

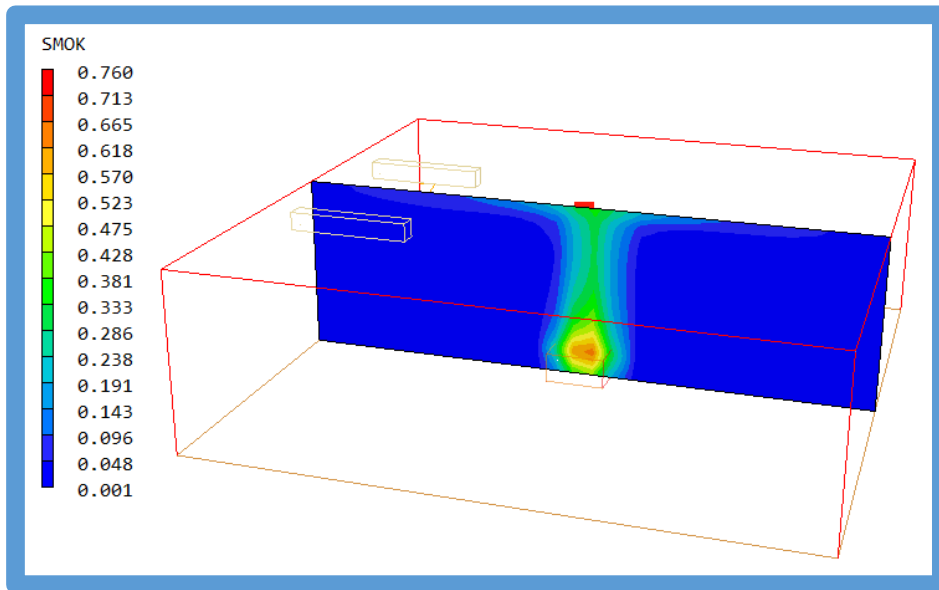

Here, any layering of the smoke is masked by the linear scale. The VR-Viewer now has a new tick-box on the Contour – Options dialog

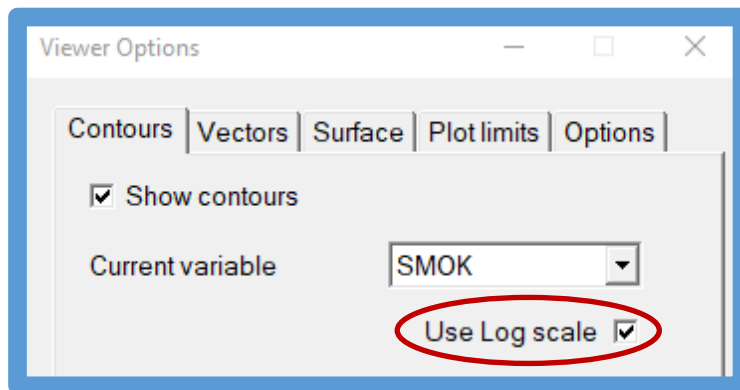

which changes the contour scale to a logarithmic scale. With the logarithmic scale, the layering becomes apparent.

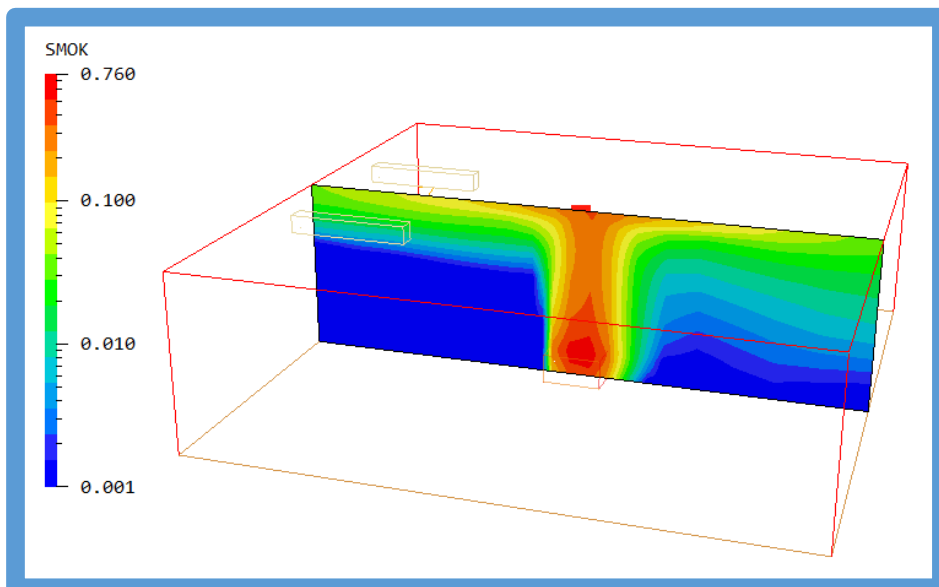

The logarithmic scales also apply to contours of a variable on an iso-surface of another.

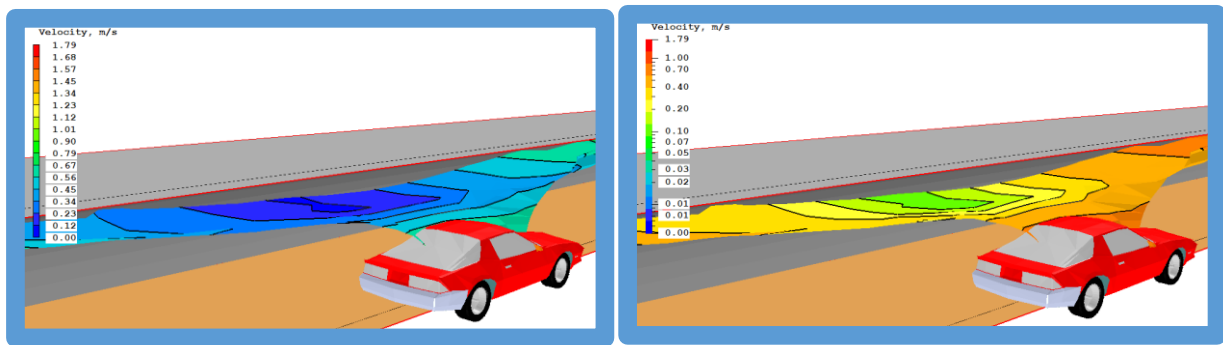

The images above show an iso-surface of sight-length (SLEN) coloured by Velocity using a linear scale on the left and a logarithmic scale on the right.

Surface Contour Improvement

When a surface contour is generated, the algorithm has to take into account the size difference between the facets used to represent the object, and the mesh used for the computation. Quite often, the facets are much bigger than the underlying cells, and have to be sub-divided to give a smoother contour. In previous versions, the sub-division size was based on the cell size at the centre of the facet.

For wind-flow cases this has proved inadequate when the cells near the centre of a large facet are big, but are smaller near the corners. This led to very blocky surface contours.

The Viewer now estimates the sub-division size as the smallest of the cell size at the centre and at each of the corners of the facet. This can lead to smaller sub-divisions and hence smoother contours.

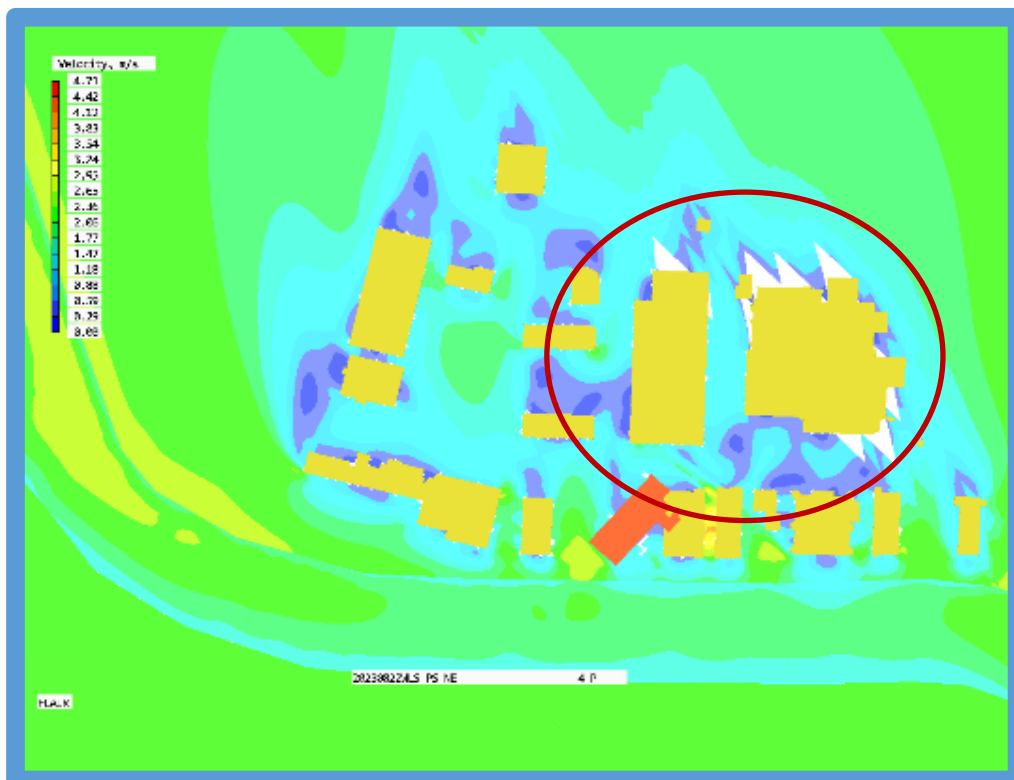

Original

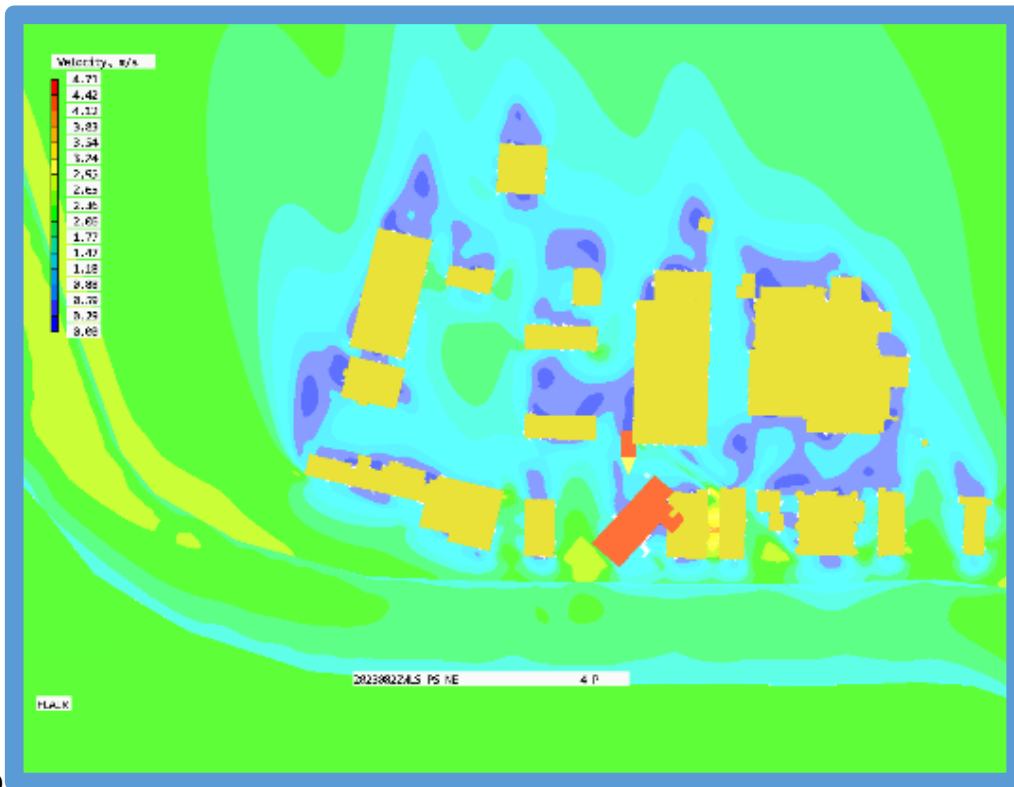

0

Corrected

Display of VTK results

The Viewer has been extended to allow it to plot results held in VTK files. This will allow the user to plot solutions produced by Unstructured PHOENICS without recourse to third-party software. The unstructured mesh can also be displayed.

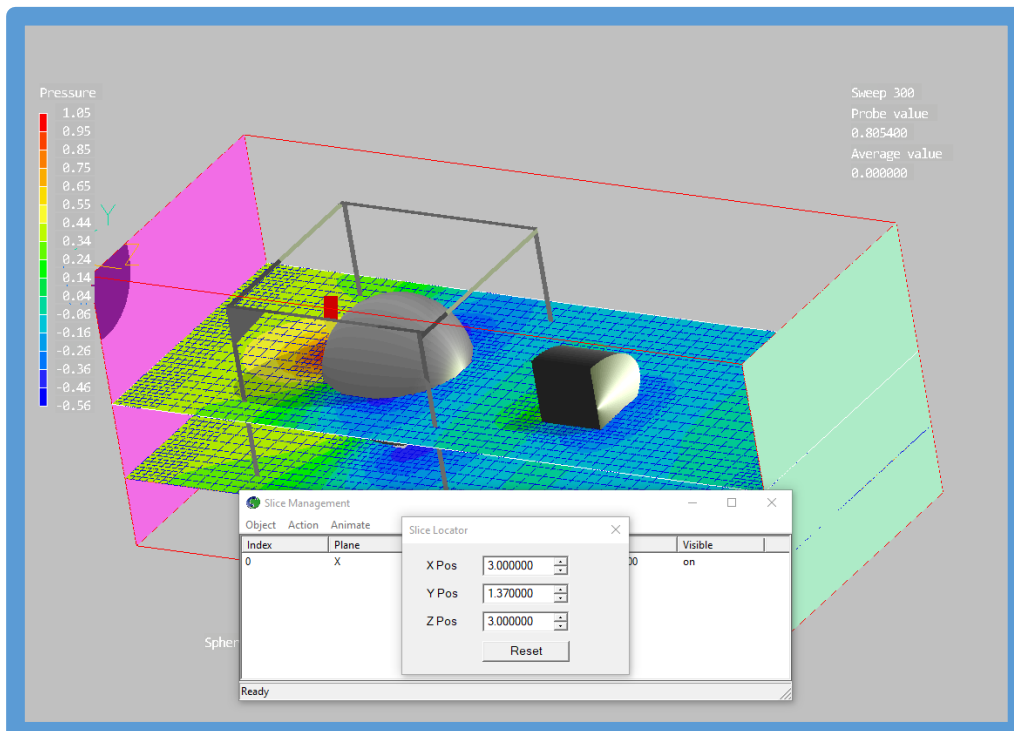

Solver – Earth

Steady State VOF

A limitation arises due to the explicit nature of the VOF method. The time step for the SURN (“colour function”) equation is often more restrictive compared to the other equations within the simulation. This constraint can slow down the convergence towards steady-state.

To achieve a Steady-State using the VOF method already implemented in Phoenix we can consider the following approaches:

1. A full transient computation with a given timestep limited by the Courant-Friedrichs-Lewy (CFL) condition until a steady state is reached;
2. A full transient computation with a different (usually smaller) time step for the colour function; or
3. A full steady computation for all variables except the colour function solved as a transient with a local time step based on the local Courant-Friedrichs-Lewy (CFL) condition.

The aim is to accelerate the attainment of the steady-state condition by manipulating the time step for each individual cell in the mesh, making it as high as possible to enable the simulation to reach steady-state quickly. In options 2 and 3, the transient solution does not simulate the physical transient development of the flow, but is a mathematical device to accelerate the solution.

For this release of PHOENICS, options 2 & 3 above have been added. Option 1 has always been available.

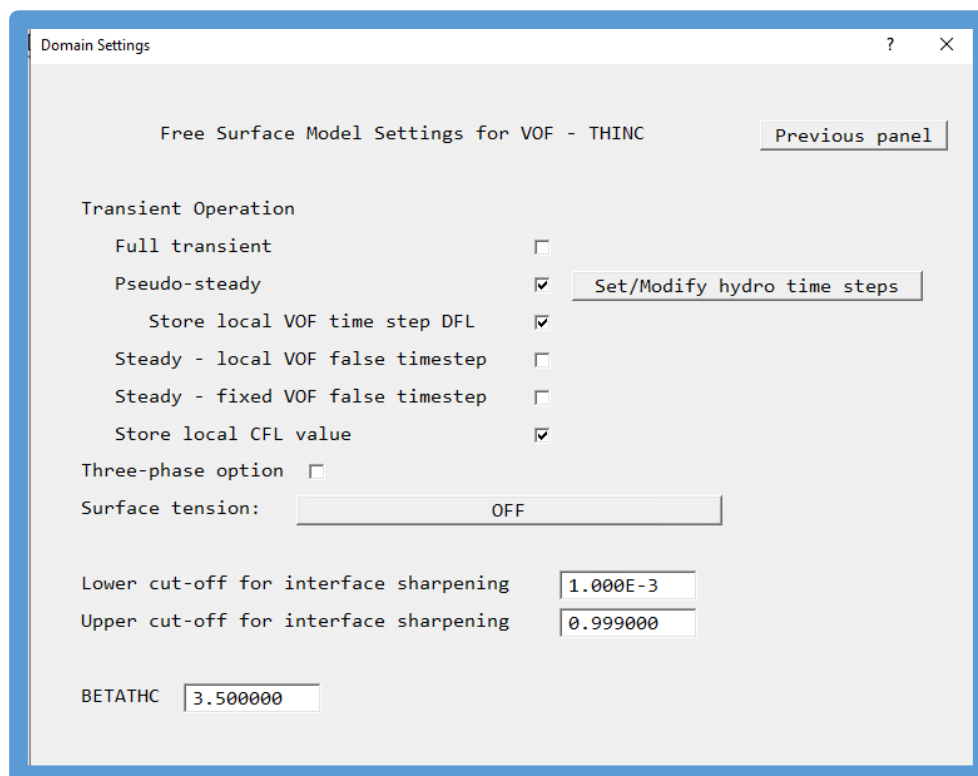

The **pseudo-steady** option implements approach 2 – all equations are solved in the normal transient manner except for the SURN (colour function) equation, which is solved using a variable local time step. This approach essentially introduces a "false" time step for the colour function.

The full-steady approach allows for two ways of setting the SURN time step:

- **Local VOF False Time Step:** The false time step varies spatially, adapting to local conditions.
- **Fixed VOF False Time Step:** A uniform false time step is applied to all cells in the simulation domain.

To compute the local (spatially variable) false time step, we compute first a local CFL and determine a False time step based on this CFL, then we determine a False time step based on sigma (surface tension) and a given false time step given by the user. The Spatially Variable False time step will be the minimum of these three false time steps. (Note that in this context a “false” time step indicates that a different time step is being used for the SURN equation – this is a different meaning from the “false time step” commonly used in relaxation.)

The SURN equation is then solved iteratively with the false time step described above. This iterative procedure is done for each sweep.

Improvements to convergence monitor

The Earth Convergence Monitor screen (GXMONI) was replaced in the 2022 release. The new, more modern, flexible, ECM allows any combination of available monitor graphs to be shown in a single window or in split screens in separate windows. It also allows various monitor windows to be positioned and sized by the User. For 2023, the following additional options have been added:

- ability to 'pin' display of figures for each plot
- ability to highlight individual curves by selecting them
- ability to save and load convergence monitor layout
- elapsed time and estimated times show minutes & seconds for short runs
- optional 'dark' mode

Disable File Numbering for Intermediate Dumps

When the Earth solver is running a long simulation, steady or transient, it is straightforward to instruct the Viewer to automatically refresh the current plot each time a new solution file is written (by right-clicking the F9 icon). This allows changes in the solution to be monitored in real time and aids in assessing convergence for steady cases - if the plot does not change from sweep to sweep, the run is converged.

For transient cases, the saved solution files can be used later to make and save animations. For steady cases the same can be done, but more often than not the saved solution files just take up disk space and are not used again.

It is now possible to switch off the saving of individual solution files for steady cases, and always just overwrite the final solution file. This preserves the ability to monitor the progress of the run in real time whilst simultaneously saving a lot of disk space.

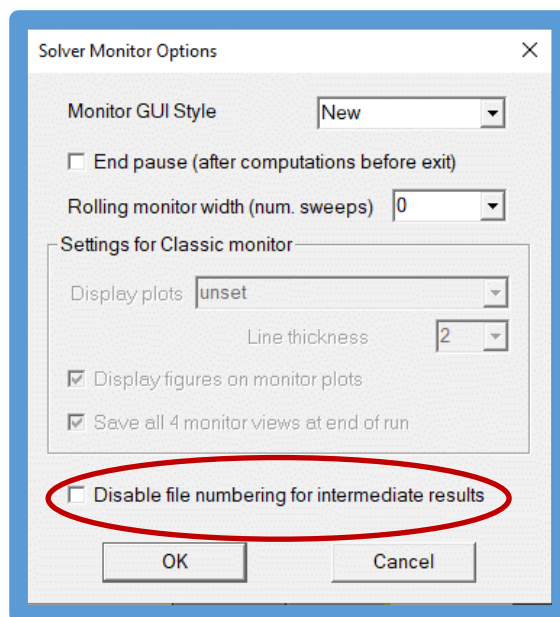

USP extension

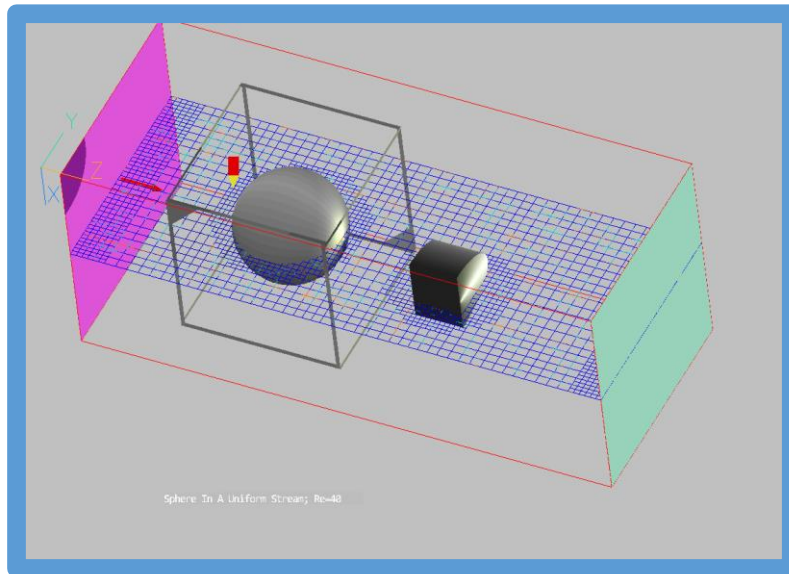

PHOENICS has hitherto always used a structured grid. An Unstructured PHOENICS option (USP) is now available. USP is computationally economic and offers flexibility in meshing which can often be very valuable. Grid cells in the unstructured version remain predominantly six-sided and, except where obliquely cut by surfaces of physical objects, the shape of which is defined by facets held in a geometry file (just as in Structured PHOENICS). The cell faces may have unequal cell numbers on opposite sides; usually one on one side and two/four on the other.

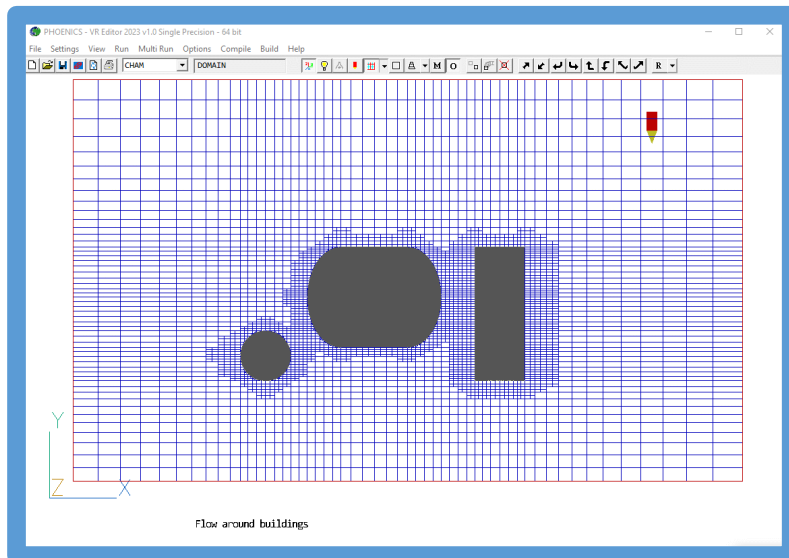

A typical UnStructured PHOENICS (USP) grid

If the domain contains both solid and fluid regions, cells in the solid parts are used only for temperature as no pressures, velocities, or other scalars are computed or stored there. Cells are not created for non-participating blockages (material 198).

UnStructured and Structured PHOENICS exist simultaneously in one executable and have much in common.

Points of similarity include:

- Problem-set-up data are supplied via a Q1 file to Satellite and via an EARDAT and FACETDAT file to EARTH;
- Calculation outputs appear in RESULT / PHI files;
- Graphical output to monitors appears similar.

Points of difference include:

- USP requires additional instructions from users regarding the grid to be used.
- Data formats written to RESULT / PHI files differ.

Features available in the version of USP included in the first release of PHOENICS 2023 include:

- Physical property formulae used in PROPS file.
- Flair Comfort Indices.
- Heat and scalar source on outside of 198 blockages.
- Compressible / high speed flow.
- Wind object.
- Flair Fire object.
- Full reporting of sources in RESULT as in SP.
- Standard K- ϵ model, Chen-Kim K- ϵ model, Realisable K- ϵ model
- Display of USP grids and solutions (using VTK) in Editor and Viewer

Parallel operation will be included in the next release.

Please see https://www.cham.co.uk/phoenics/d_earth/d_opt/d_usp/inplib/howtousp.htm for more details on USP.

Corrections

The following issues have been corrected:

VR-Editor

- Improve detection of domain material name for BLOCKAGE using domain material.
- Increase internal string lengths to cope with long error messages.
- Allow for very long strings in input boxes.
- Allow for blanks in the name of the private solver.
- Correction to menu dialog display for Bingham and Power-law fluids.
- For fixed-flux scalar sources at 198 blockages the 'Total flux' / 'Per unit area' flag was not echoed to Q1, so all subsequent runs assumed 'Total flux' – but see Earth bugs below.
- Surface heat balance allowed for transient case – internal error caused the setting to be discarded.

VR-Viewer

- Improve the capture of text when saving VBO images.
- Internal improvements to prevent hangs caused by simultaneous incompatible operations e.g. starting a line plot when an animation is still running.
- Correct a long-standing issue when saving animations with 'Threaded animation' off.
- Correction to the scaling of vector arrowheads when the domain is scaled. A bug introduced with 2022 resulted in the arrowheads being very wide.

Earth - Solver

- Allow porous plate with pressure-drop to run in parallel.
- Allow GROUND/InForm-set specific heat to use previous sweep value to derive current sweep (e.g. for solidification models).
- Resolve occasional internal conflicts between object named TABLE and InForm TABLE command.

- Correct an error in the source inflow/outflow reporting in parallel, to ensure that values from halo cells are not used.
- Prevent occasional hang when saving files in parallel.
- Correction to ANGLED_IN/OUT not to test for surface area outside the domain
- Replace TMP1C with ENUL1C for ENUL=GRND7 (laminar viscosity step function of temperature)
- Corrections to VOF contact angle
- In the Flair Drift Flux Model, failing to create aerosol variables becomes a fatal error.
- For CP1=GRND6 (specific heat for phase change material) switch between 'at constant temperature (dTabs=0)' and 'over range (dTabs=1)' was the wrong way round.
- For a fixed-flux scalar source at a 198 BLOCKAGE, the 'Total flux' / 'Per unit area' flag was interpreted the wrong way around.
- Correction to the sources applied to an object within the scope of a ROTOR object. The source was always applied at the 'time 0.0' location, not the current location. There was also an indexing error in the solver linked to faceted objects inside a ROTOR which could lead to erroneous temperature solutions. The correction was extended to allow all sources within the scope of a ROTOR to move – previously only sources from blockages would move.
- In parallel, prevent an occasional hang at start up caused by loss of synchronisation between processors whilst analysing objects/patches.
- Correction to a long-standing internal problem which would occasionally cause a parallel run to stop with a 'Problem with geometry detection - insufficient grid?' error message.
- The optional MUL Store for dynamic viscosity was not filled when InForm was used to set the kinematic viscosity ENUL.



Items in PHOENICS 2022 v1.0.2 (December 2022)

The December release of PHOENICS 2022 primarily contains a few corrections for issues noted with the initial release. The items new in 2022 compared to 2021 are listed [here](#).

Solver – Earth

- **New** – in the Earth Convergence Monitor the display of numerical values can be ‘pinned’ so that it does not disappear when focus is switched to another monitor window.
- Correction to the calculation of the residual normalising factor (RESREF) for KE. For 2022 an error resulted in the normalising factor being too big, and hence the KE residual was reported as smaller than expected. The effect on the final solution is minor. This affected the Chen-Kim, RNG and Realisable k- ϵ models.
- Correction in parallel to the calculation of the open area or volume of an object when the object with the source exists on more than one processor and is partially covered by a blockage. This could result in the mass source at an INLET being incorrect. If the object only exists on one processor or it is not partially obscured the source was correct.
- Change the test for checking the MOFOR time limits to prevent having to artificially add time periods to the MOF file to cope with restart runs that start at Time>0.
- For MOFOR allow the calculation of diffusion/conduction inside moving objects for variables with no convection term (e.g. EPOT). Variables with active convection terms are still zeroed and not plotted.
- Correction to the calculation of VOF surface tension as function of temperature for 2D cases. 3D cases are unaffected.

VR Editor and Viewer

- **New** - a lighting icon  has been added to the toolbar . A left-click brings up the Graphics Options dialog, a right-click toggles the VBO shadows on/off.
- Correction to the location of INLET/OUTLET/PLATE objects located 'at_start' when the domain origin is not (0,0,0). The WIND object is not affected.
- Add the domain origin offset when moving the probe to the centre of an object.
- Allow EPOT and variables with names starting # to plot inside MOFOR objects with OBID>0.
- For GENTRA allow the user-set relaxation of VAPO/MH2O to be preserved. Previously this was always reset to the default GENTRA source-term relaxation.
- The size of the geometry files in Basic_shapes\Furniture has been reduced to speed loading.
- The quality of saved images and animations using the VBO shader has been improved.

Flair

- Correction to the summing of the domain free-volume in parallel.
- Correction to the summing of the domain inflow-fluxes in parallel. These are used to report the domain residence time.

Items in PHOENICS 2022 v1.0 (September 2022)

Solver - Earth

3-PHASE VOF

VOF is extended to allow for 3 distinct phases – gas/liquid/gas, liquid/gas/liquid, liquid/liquid/liquid or gas/gas/gas. The extension to three fluids involves the solution of a conservation equation for an additional colour (or indicator) function, SRN2, to represent the third phase; and a modification of the surface-tension force in the mixture momentum equation to handle the three distinct fluids.

- Heat transfer between all three phases and immersed solids is considered.
- Surface tension between all three phases is included.
- Marangoni effects (variable surface tension) for all three phases are included.
- The speed of operation of VOF has been increased by only calculating the free surface position(s) on the first sweep of each time step.

The implementation of the static contact angle for wall adhesion effects has been improved. The following images compare ANSYS and PHOENICS solutions for the slug flow of water and kerosene

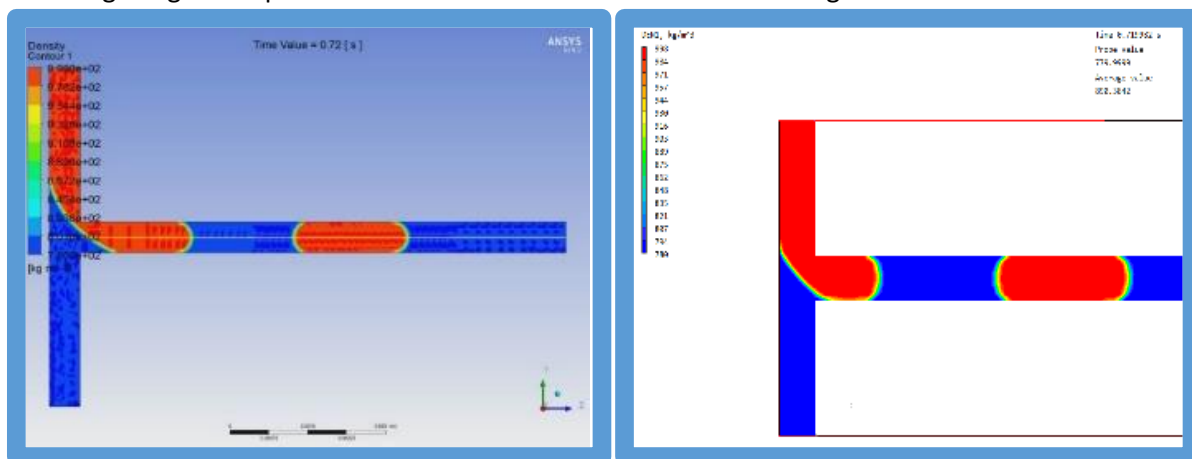

The following images show a heavy drop falling into a light drop through lighter-still fluid.

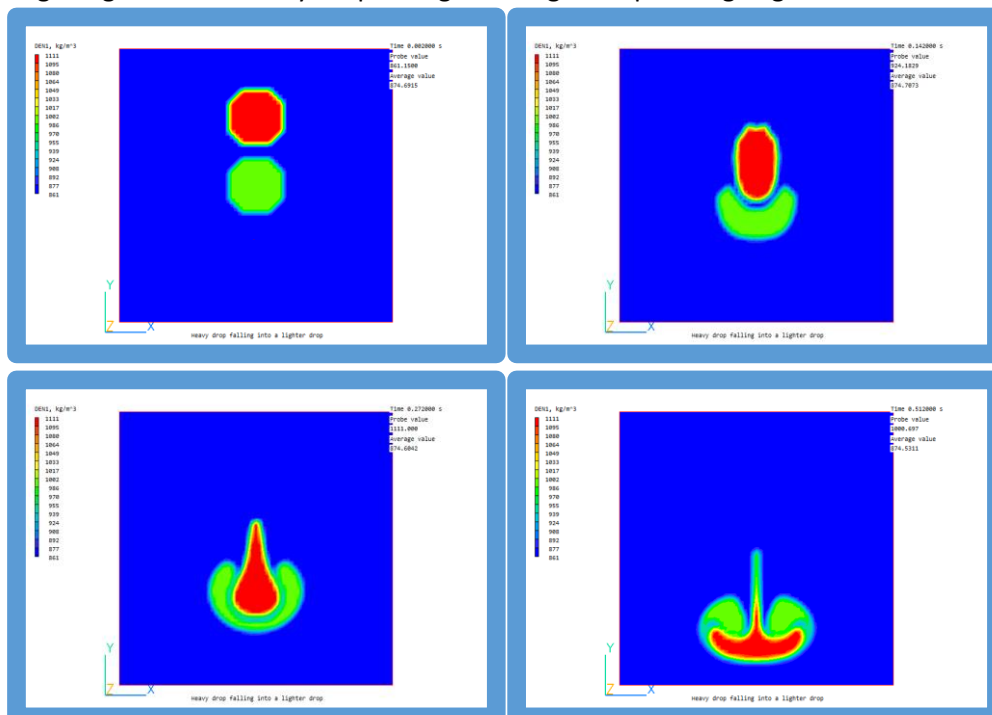

Further 2- and 3-phase VOF examples can be found online at https://www.cham.co.uk/phoenics/d_polis/d_applic/applic.htm#VOF.

Extended range of Non-Newtonian fluids

Eight, additional, non-Newtonian models are coded into PHOENICS-2022 equipping it with a wide range of menu-driven models including standard versions of:

- Power-law,
- Sisko,
- Cross,
- Carreau,
- Carreau-Yusada (CY),
- Powell-Eyring,
- Bingham Plastic,
- Herschel Bulkley,
- Casson and
- Ellis.

These models facilitate simulation of an extensive range of fluids including blood, clay, foods, greases, mud, polymers, sewage sludge, and slurries.

The models are documented in POLIS and validated via library cases for tube flow. Optional functions have been provided, documented and tested for temperature-dependent rheology used by PHOENICS to handle variants of Power-law/Cross/ Carreau/CY fluids. PHOENICS results for all fluid types compare favourably with analytical and/or numerical solutions, including those for the Graetz problem for heat transfer to a polymer melt with viscous dissipation at high Brinkman number.

The PHOENICS upgrade includes the Papanastasiou regularisation for viscoplastic fluids, which improves the convergence rate when simulating the flow of these fluids, especially at high Hedstrom/Yield numbers.

The following images show a radial velocity profile and an axial pressure profile for the flow of a Herschel-Bulkley fluid at a Reynolds number of 10 and a Yield number of 2 through a pipe.

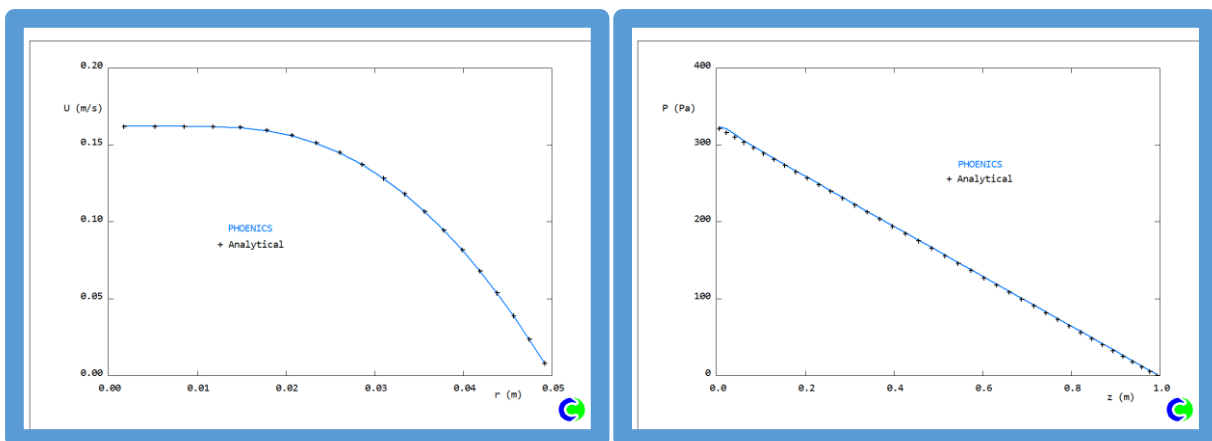

Sutherland's Law for thermal conductivity

This provides another option for calculating temperature-dependent thermal conductivity of a gas. Values of constants for several common gasses are provided.

Particle-cluster 4-zone fluidisation drag model for IPSA

In this new model a fluidised bed is characterised by four different flow regimes, namely:

- the dense regime, $R_c \leq 0.8$,
- the sub-dense regime, $R_c > 0.8$ and ≤ 0.933 ,
- the sub-dilute regime, $R_c > 0.933$ and ≤ 0.99 and
- the dilute regime, $R_c > 0.99$

where R_c is the critical volume fraction. A blending function is introduced to provide a smooth transition between the various flow regimes.

New Convergence Monitor

The Earth convergence monitor, known as `gxmoni`, has been rewritten to display multiple convergence curves in a tabbed window:

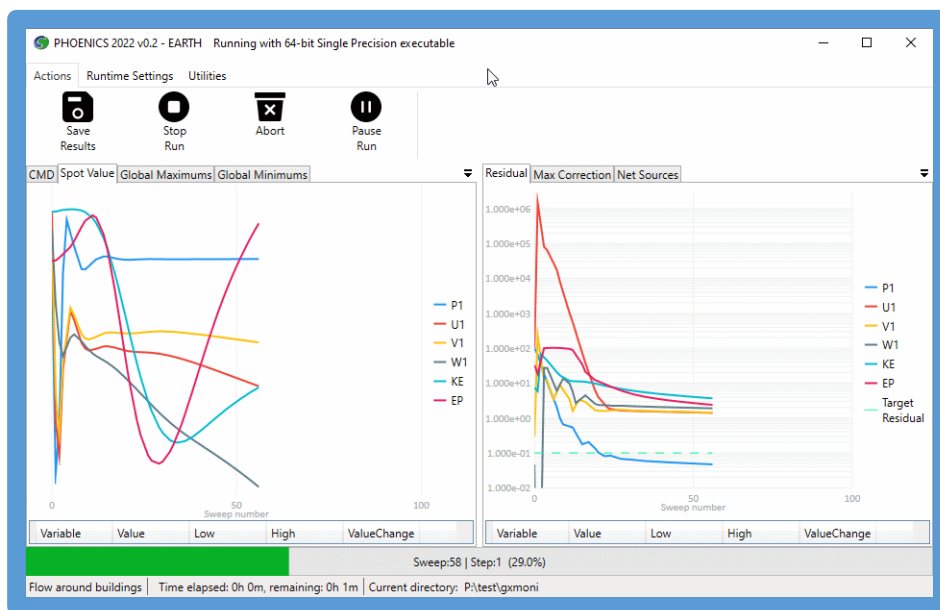

The individual tabs display, as a function of sweep:

- '**CMD**'- text output from the solver
- '**Spot value**'- the values of all variables at the selected monitor point
- '**Global Maximums**'- the largest value in the domain
- '**Global Minimums**'- the smallest value in the domain
- '**Residual**'- the normalised sum of errors for each variable
- '**Max Correction**'- the largest correction between iterations
- '**Net Sources**'- the net sum of sources for all variables

Each tab can be displayed by clicking it. Alternatively, the tabs can be pulled out to make individual windows. In this way all six plots can be displayed simultaneously if so desired.

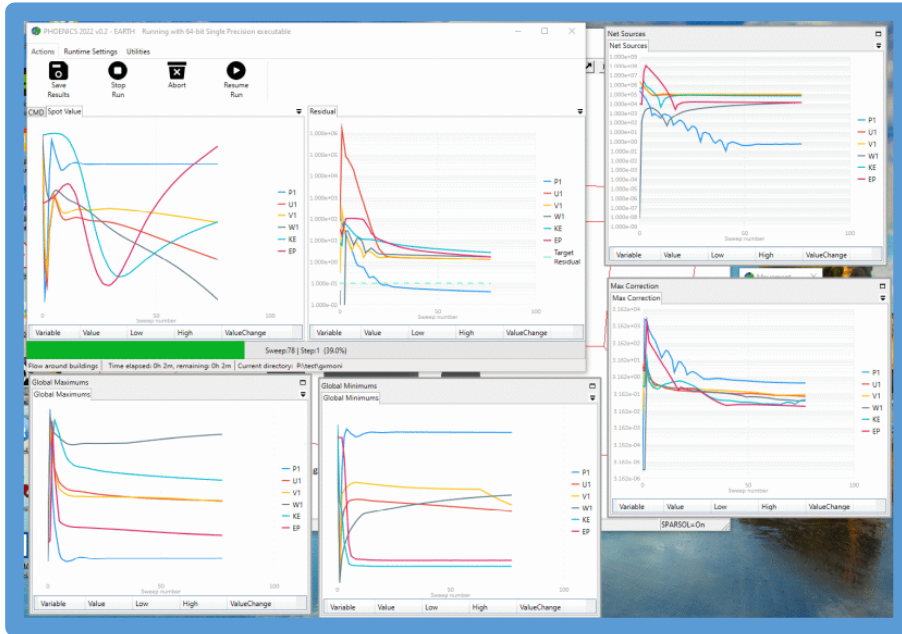

The ribbon along the top of the window is split into three sections,

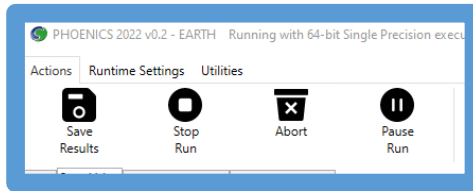

- **Actions**, which provides icons to:
 - Save Results
 - Stop Run
 - Abort
 - Pause Run

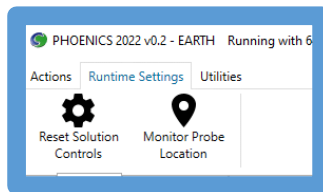

- **Runtime settings**, which provides icons to:
 - Reset Solution Controls
 - Monitor probe Location

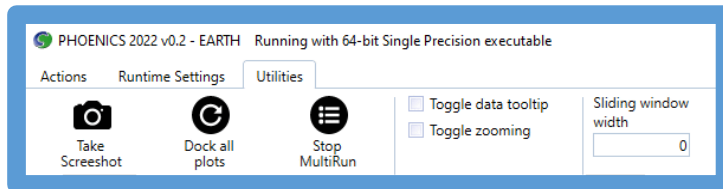

- **Utilities**, which provides icons to:
 - Take Screenshot
 - Dock all plots
 - Stop Multirun
 - Toggle data tooltip
 - Toggle zooming
 - Sliding widow width

The 'classic' solver convergence monitor (the GXMONI screen) can be recovered by adding the line:

```
SPEDAT (SET, GXMONI, CLASSIC, L, T)
```

to Group 19 of Q1. If the line is absent, or has 'F' instead of 'T' as the last argument, the new style will be used. This can also be done from within the VR Editor by selecting 'Classic' on the [Options - Monitor options](#) dialog.

A more detailed description of the convergence monitor is given online here https://www.cham.co.uk/phoenics/d_polis/d_enc/gxmoni.htm.

Print viscous heating source

This allows for a more accurate determination of a full heat balance from the energy sources printed to RESULT. The extract from RESULT below

```
DP/Dt contribution to      TEM1 nett source      ==-4.657418E+02 (Flx Out -4.091813E+03 In
3.626071E+03)
Nett source of TEM1 at patch named: OB1      (INL      ) = 1.974167E+04 (Average 1.093333E+03)
Nett source of TEM1 at patch named: OB2      (OUTL      ) ==-2.147481E+04 (Ave Out 1.213151E+03 In
0.000000E+00)
Nett source of TEM1 at patch named: *-3NFAC  (NCLOSS    ) ==-5.855948E+01
Nett source of TEM1 at patch named: *RADN    ) ==-1.573581E+03
pos. sum=1.974167E+04 neg. sum=-2.357269E+04
nett sum=-3831.019531
```

appears to show an energy imbalance of 3.8kW, nearly 20% of the inflow value. The revised printout

```
DP/Dt contribution to      TEM1 nett source      ==-4.673550E+02 (Flx Out -4.096696E+03 In
3.629341E+03)
Viscous heating term      TEM1 nett source      = 3.821803E+03 (Flx Out 0.000000E+00 In
3.821803E+03)
Nett source of TEM1 at patch named: OB1      (INL      ) = 1.974167E+04 (Average 1.093333E+03)
Nett source of TEM1 at patch named: OB2      (OUTL      ) ==-2.146920E+04 (Ave Out 1.212761E+03 In
0.000000E+00)
Nett source of TEM1 at patch named: *-3NFAC  (NCLOSS    ) ==-5.851753E+01
Nett source of TEM1 at patch named: *RADN    ) ==-1.570893E+03
pos. sum=2.356347E+04 neg. sum=-2.356596E+04
nett sum=-2.492188
```

shows that virtually all the 'missing' heat is actually accounted for by the viscous heating term, leaving an energy imbalance of 2.5W, or 0.013%.

Flair / Flair-EFS

PET comfort index

The Physiological Equivalent Temperature (PET) is a thermal comfort index that is based on a prognostic model of the human energy balance that computes the skin temperature, the body core temperature, the sweat rate and, as an auxiliary variable, the clothing temperature.

PET is based on the Munich Energy-balance Model for Individuals (MEMI) and used to model the impact of heat, wind, etc on the body to create a comfortable human environment.

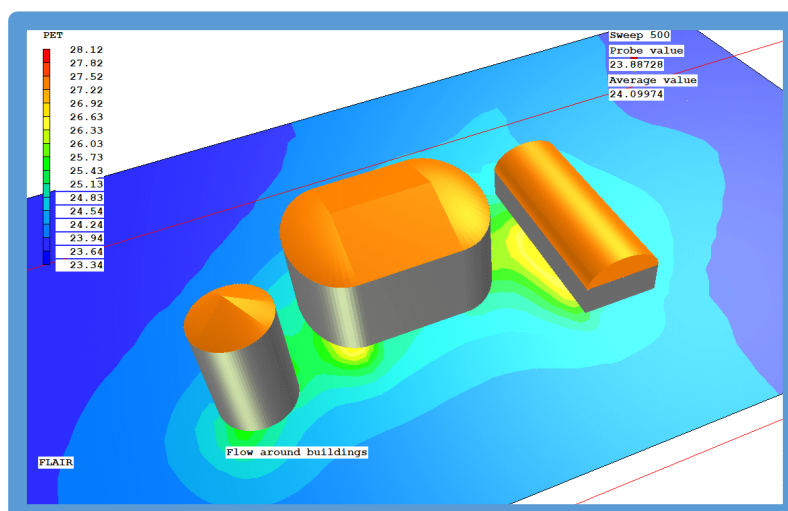

Thermal Sensation Index (TSI)

TSI is an empirical model developed by studies conducted in the context of Japan. It considers five climatic factors— air temperature, horizontal solar radiation, wind speed, relative humidity and mean radiant temperature— at a given location and time. TSI’s prevalence in Hong Kong can be explained by its user-friendly nature. Particularly, it is the index that public housing projects in Hong Kong adopt. We have implemented a simplified version according to BEAM Plus New Buildings Version 2.0.

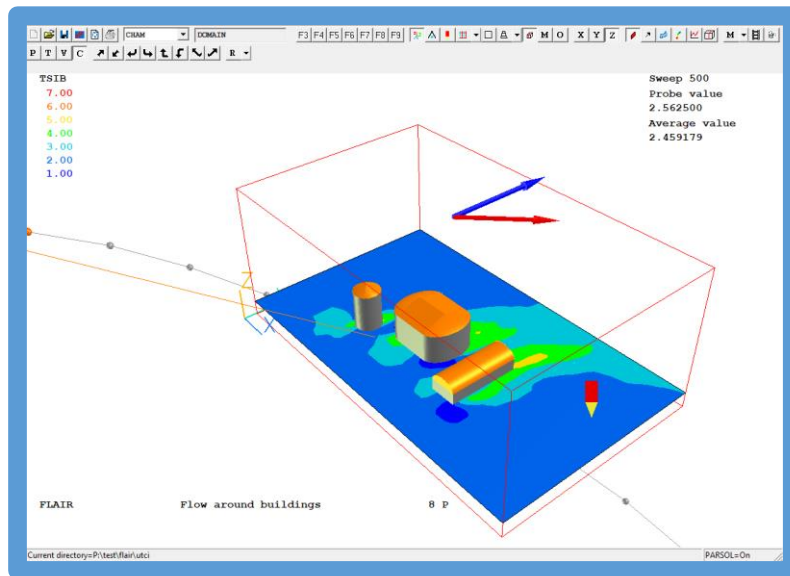

TERRAIN Object

A new class of object – TERRAIN – has been introduced for Flair. The aim of this is to simplify the settings required for external wind-driven flows. Users become confused how to set the wall roughness for objects representing buildings and objects representing the ground. The TERRAIN object makes the correct settings by default (wall functions set to fully-rough, roughness height defaulted to 0.03 - Open flat terrain, grass, few isolated obstacles) and where possible offers to copy ground plane boundary-condition settings from the WIND object. The option of ‘Fully rough’ is removed from the list of global wall functions, as these must not be used for buildings.

VR Editor

FOLIAGE Object

A drag coefficient for ‘small plants’ has been added to the list of vegetation types.

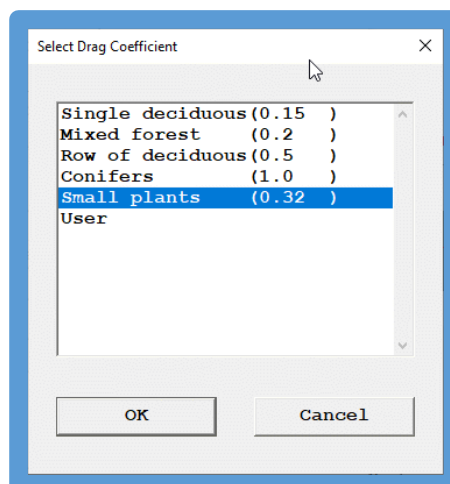

Corrections

VR-Editor

- Default number of solver iterations for pressure (LITER(P1)) increased from 20 to 200 when automatic convergence (CONWIZ) is off.
- Default surface roughness for WIND object changed to 0.03 - Open flat terrain, grass, few isolated obstacles. This was 0.0002 – Open sea.
- Corrections to 'PERSON' object when in 'user' posture to prevent unexpected size / position changes.
- When changing CELLTYPE to USER_DEFINED, ensure flag is set so object does not affect the grid.
- Corrections to display of probe location / value when domain origin is offset from zero – also affects probe value extraction using macro.
- Corrections to polar geometry files polhalfcylinder.dat and polquatercylinder.dat.
- Correction for emissivity of 198 blockage disappearing after 'Save working files'.

VR Viewer

- In Viewer, the streamline, slice management and plot limits were found not to allow for non-zero domain origin.
- Improvements to the speed of VBO rendering, and screen capture.

Solver

- Correction to area source applied by volume object.
- Correction to VABS calculation next to blockage one cell ahead.
- IMB1 is now mass error regardless of CONWIZ=T/F. Previously was volume error for CONWIZ=T, mass error for CONWIZ=F.
- Correction to IPSA phase-diffusion flux for Sparsol.
- Correction to SUN object when #QS2 is not STORED.
- Correction to pressure and friction integration.
- Correction to THINPLT in parallel, to allow object to be on edge of sub-domain.
- Correction to new PBP solver in parallel to add missing exchange of halo values.
- Correction to default parallel solver to get full exchange of values in diagonal halo cells where 4 / 8 processors meet.
- Correction to object detection in polar when part of object lies outside domain.
- Allow detection of cut cells for VOF regardless which fluid is domain fluid. Previously would only detect cut cells if domain fluid was 'heavy'.
- Avoid potential out-of-bounds array error when sorting intersections along a gridline for Sparsol.
- Correction to residual normalising factor for OMEG – add sources from KWSOURCE patch.
- For 2D-XY cases recalculate mass inflows for variables coming after TEM1, as the inflow mass flux will have been multiplied by specific heat.
- When MOFOR is active, memory for 3 arrays was allocated at the start of each step even though these arrays already existed leading to ever-increasing memory usage. For large grids with many timesteps this can eventually lead to memory allocation errors.
- When restarting with a different grid, don't interpolate the PRPS marker but force a re-detection of objects on the current grid

Flair

- For 2D-XY cases enable calculation of Flair Comfort Indices.

Items in PHOENICS 2021 v1.0 (August 2021)

Graphics Update – Common to Editor and Viewer

For many years the Editor and Viewer have used traditional OpenGL display lists to create the on-screen graphics. Modern OpenGL graphics have a better appearance due to the use of Shader programs which can be actioned on many GPU's simultaneously. PHOENICS 2021 will use Vertex-Buffer-Object (VBO) oriented graphics which implements shader programs.

The choice of graphics rendering is made on the new **Settings - Graphics Options** dialog, which replaces the old **Settings – Adjust lighting** dialog.

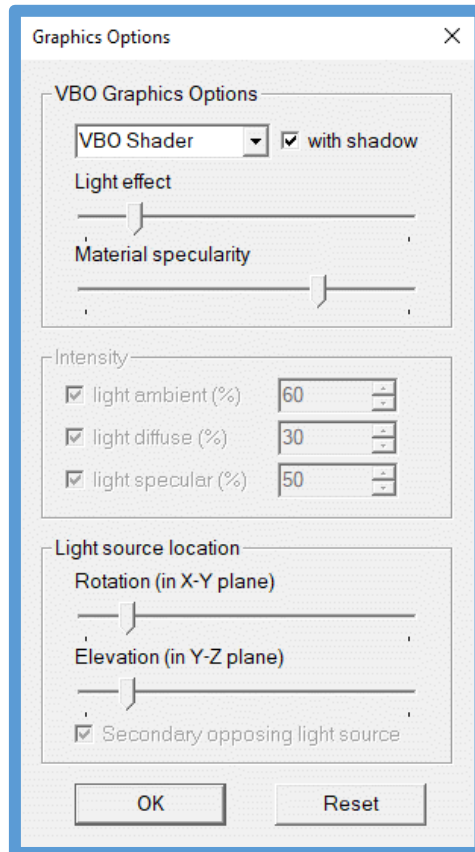

The use of VBO-based graphics allows for ('Legacy' OpenGL on left, VBO on right):

- Smoother shading;

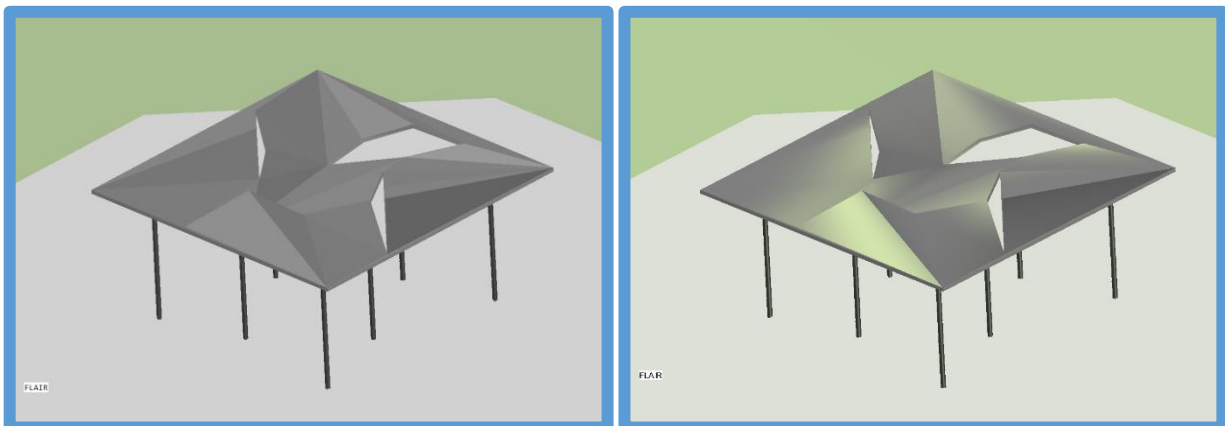

- Better handling of transparency, especially when multiple transparent objects overlap;

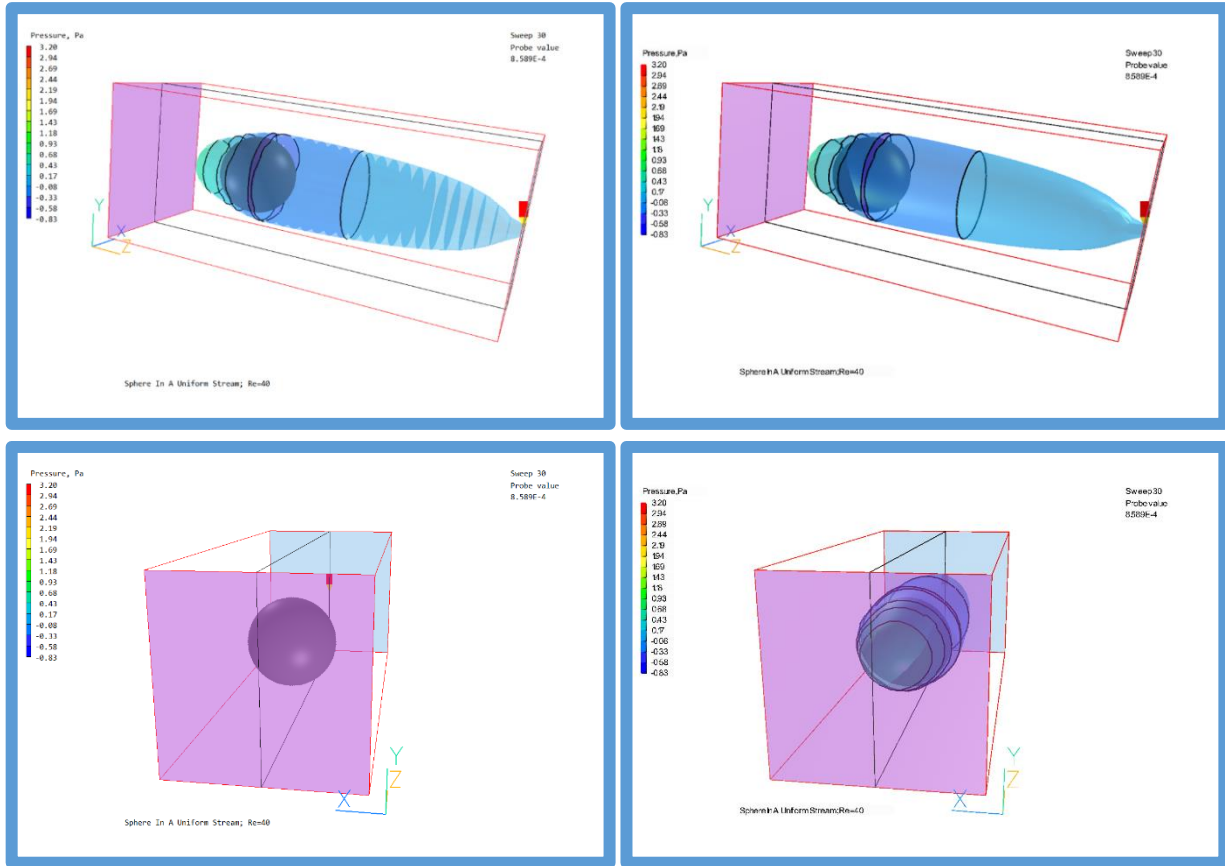

- Objects can cast shadows (linked to the SUN position if a SUN object is present);

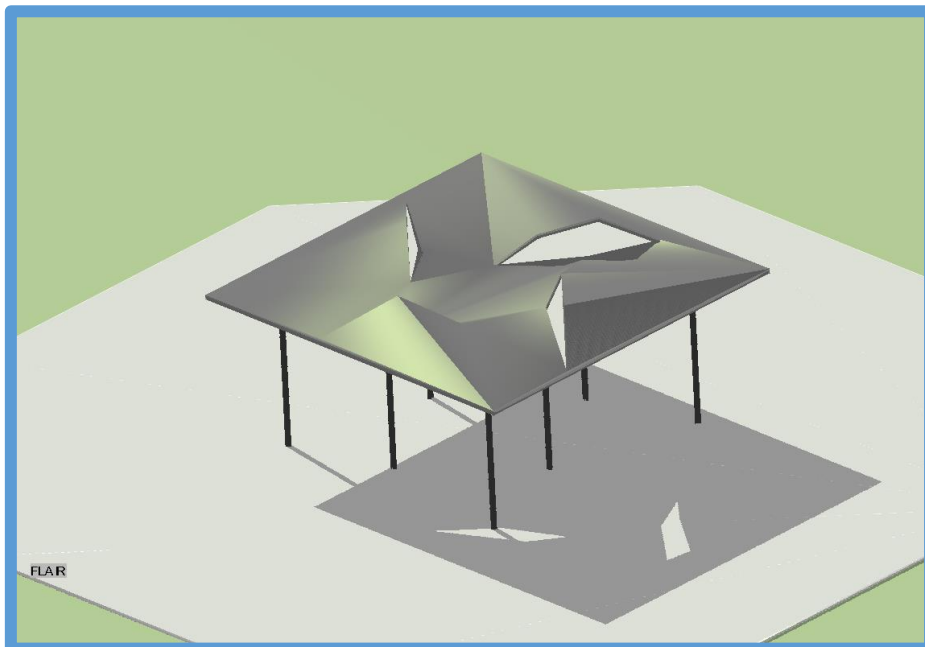

- Edges of objects can be highlighted (cartoon-like drawing)

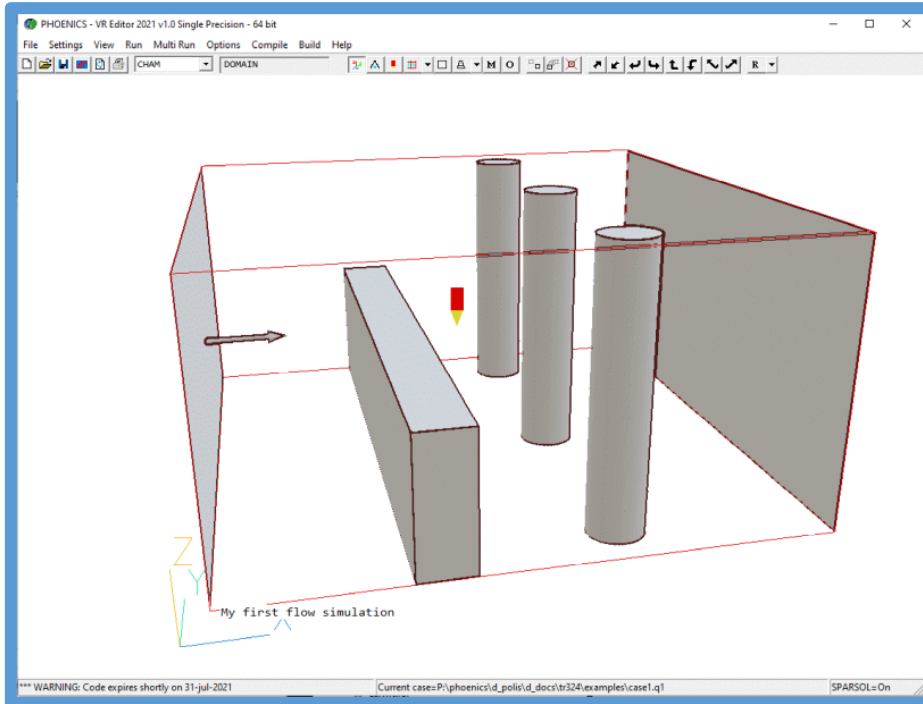

If the graphics card does not support VBO shaders, PHOENICS will revert to using the legacy OpenGL graphics. The chosen renderer is saved to the local CHAM.INI.

VR-Editor

Domain origin

The Domain Origin can be set to any arbitrary location, including the negative quadrant

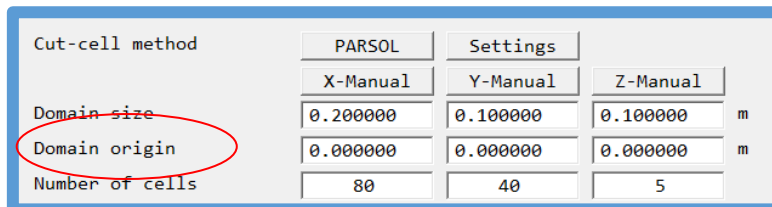

The gridmesh dialog has new input boxes for the domain origin, which can be in the negative quadrant. In previous versions, to move all objects closer or further from the origin meant making a group of all objects and then moving them all. Now, it is a simple task to just move the origin (remembering to make the domain larger if need be!)

Object Position

The position of an object can be tagged to be 'At start', i.e. at the start of the domain irrespective of the domain origin position. Domain-face objects created through the 'Main Menu – Domain Faces' panel are automatically tagged 'at start' (or 'at end') to ensure they stay at the domain boundaries.

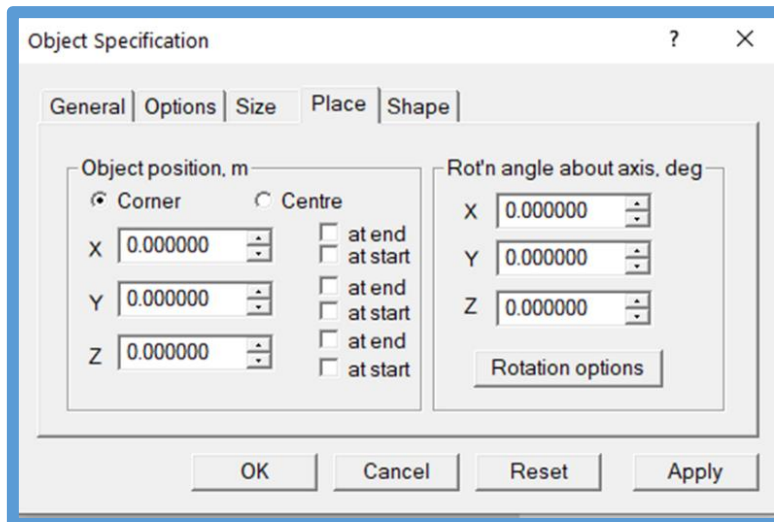

Object Geometry Library

The object geometry library has been cleaned up, with easier access to basic primitives simplifying the task of building geometries.

The first screen displayed when searching for a shape shows the folder 'Basic Shapes', containing primitives such as box, cylinder, sphere etc.

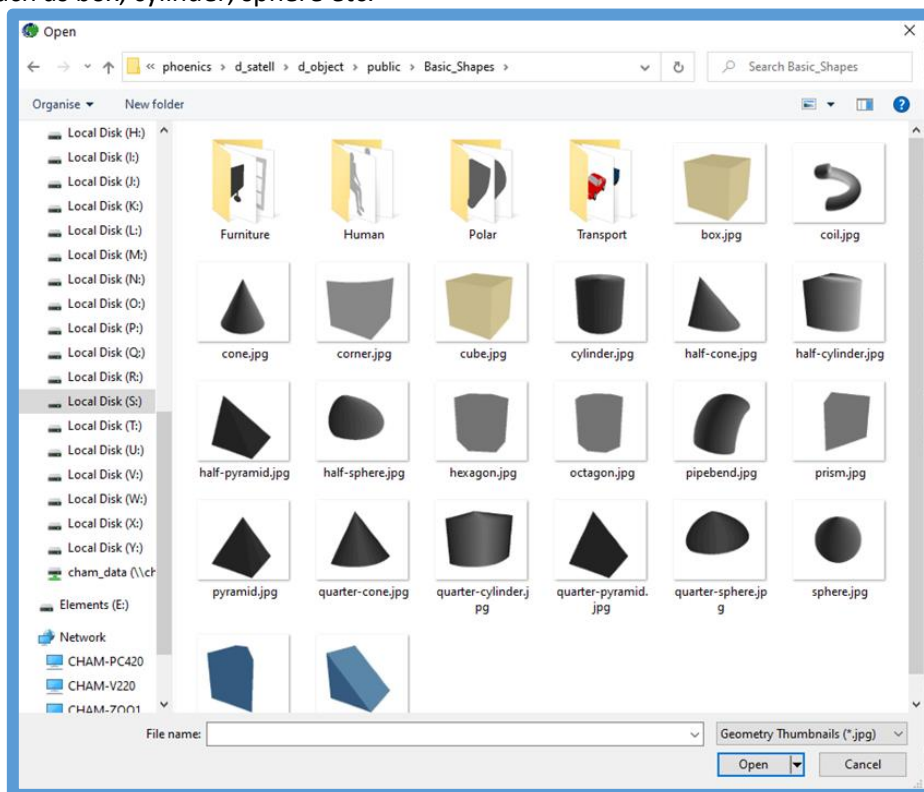

Other more commonly-used shapes are in subfolders, while more 'exotic' shapes are one level up in the 'Public' folder.

CAD Import

The import of groups of CAD geometries has been improved – the relative positions are no longer influenced by the order of geometry-file selection.

If the object(s) are to be located at the CAD location, and that is in the negative quadrant, the domain origin (and potentially) size are reset to just enclose the new object(s).

Several groups of objects can be imported maintaining the relative positions between all the groups.

Linked Angled-in Objects

For linked ANGLED_IN objects, it is possible to set the minimum and maximum values of Temperature and scalars at the exit. The default values are the minimum and maximum values allowed for the variable in question.

This will prevent the exit temperature from a cooler dropping below the temperature of the cooling coils, or the exit temperature from a heater exceeding the temperature of the heating element.

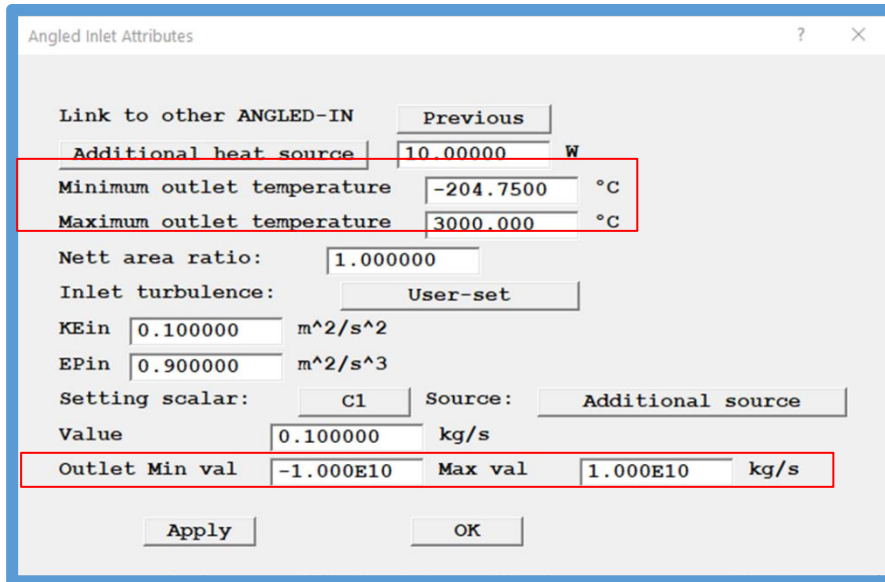

A range of additional sources can be applied to temperature:

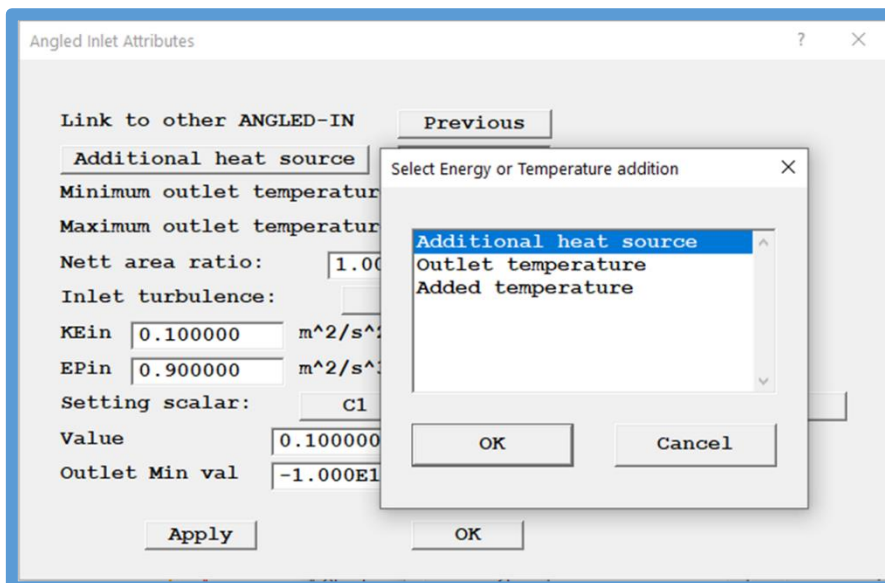

Cooling can be implemented by setting negative values for 'Additional heat source' or 'Added temperature'.

The additional sources for scalars are:

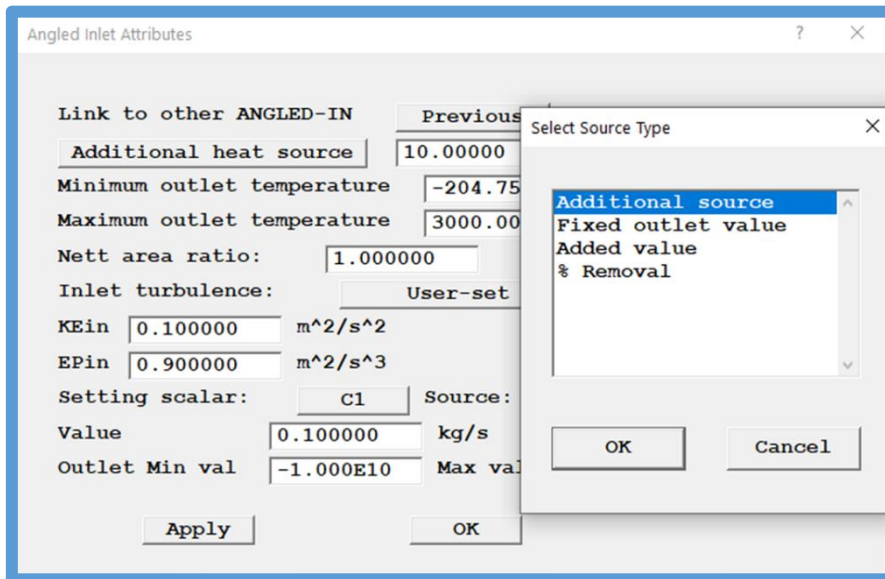

Track_counter Object

A new object type TRACK_COUNTER has been introduced. This counts the number of GENTRA or Viewer streamline tracks passing through.

In the Viewer, the intersection points and start points of the tracks are shown in the graphics display as green and red balls.

The number of tracks passing through, and the flight times are displayed in the 'Show results' window.

For RAIN tracks, the mass flow and droplet size of each track is also shown.

FOLIAGE Object

For PHOENICS 2020, additional sources of heat and moisture (for Flair) were added. The source specified had to be multiplied by the Leaf Area Density (LAD) prior to input. This was tedious, and not compatible with a height-varying Leaf-Area-Density. This multiplication is now performed internally by the Earth solver, so the sources input are per unit LAD. In addition, sources for any solved scalars can also be set.

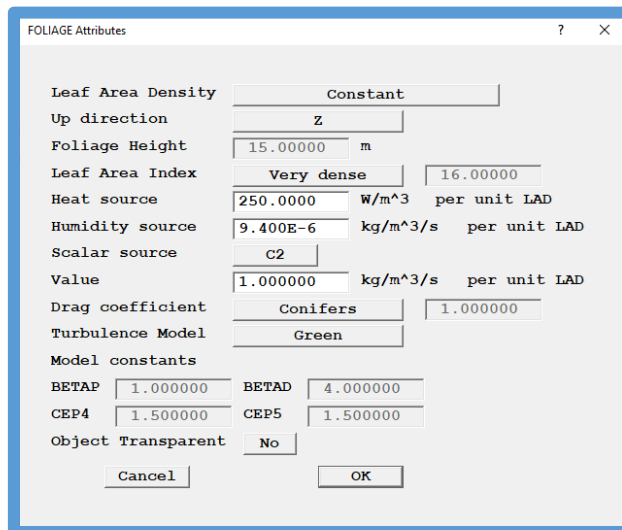

If a Q1 generated with PHOENICS 2020 is encountered, the heat (and humidity) source will be divided by LAD when the Q1 is read in, thus preserving the total heat source applied.

Editor Corrections

Display of CLIPPING_PLANE object in Polar co-ordinates fixed.

Corrections to storage of TRU1 for multiple ROTOR objects. Allow for U velocity relative to each rotor for multiple ROTORS.

In the GRIDMESH dialog the number of regions displayed per screen is increased from 5 to 10. The total number of cells in the model is echoed to the bottom of the dialog.

For INLET and ANGLED_IN dialogs, if the flow direction is detected as outflow, the external value input boxes are greyed out as they are irrelevant.

For objects with more than 999999 facets, the format of the entry in FACETDAT has changed from I7 to I8 to allow up to 99999999 facets.

Facetted USER_DEFINED and CELLTYPE objects with no attached PATCH commands are no longer written to FACETDAT.

Allow for longer lines (1024 characters) when editing InForm commands.

VR-Viewer

Track_counter Object

The TRACK_COUNTER object has been added to the list of objects that can be created in the Viewer as well as in the Editor. As mentioned above, the TRACK_COUNTER counts tracks that pass through it, and reports the time of arrival of each track.

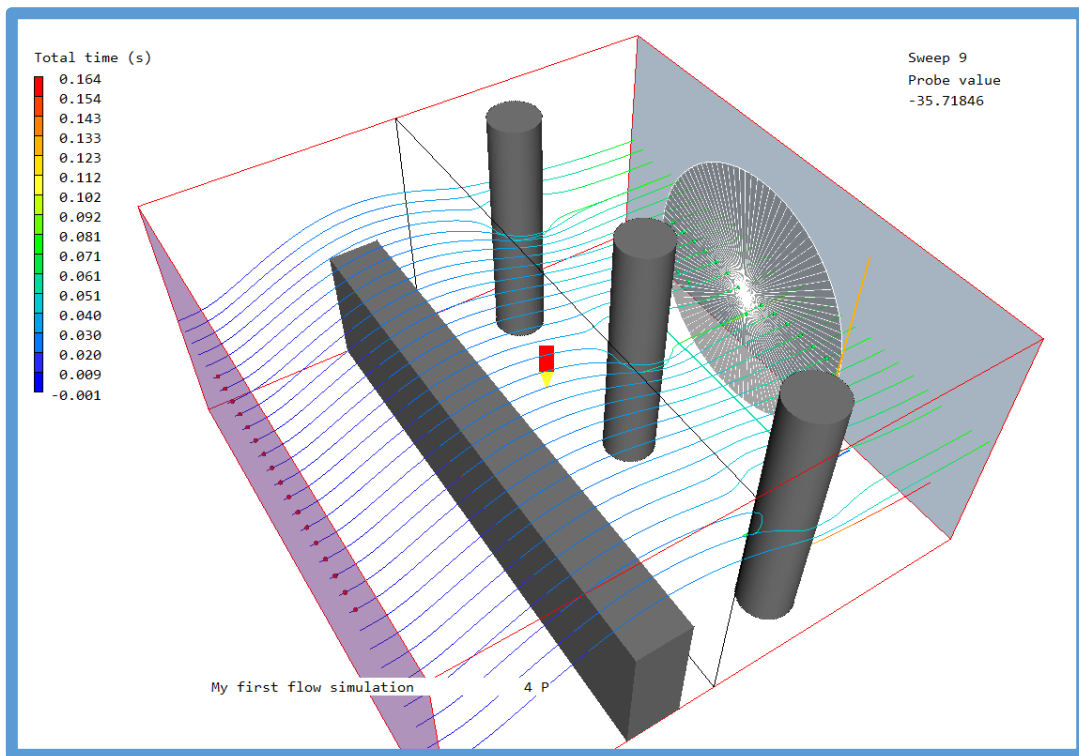

The green balls mark where tracks pass through the counter, and the red balls mark the start points of the tracks. The arrival times can be displayed by right-clicking the required tracker object and selecting 'Show net sources'; or opening the Attributes dialog of the required tracker and pressing 'Show'.

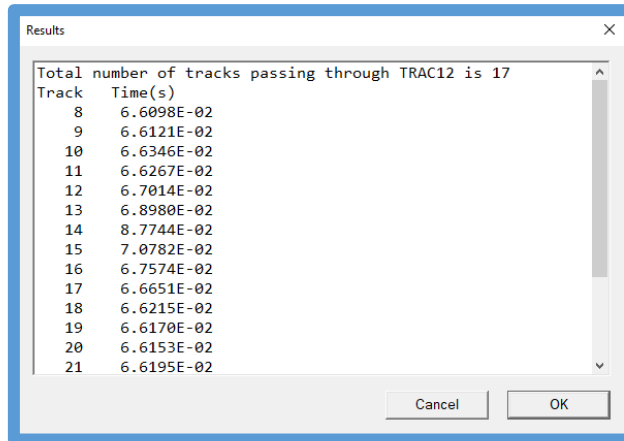

Streamlines

Individual streamline tracks (or selected tracks) can be coloured by flight time, current plotting variable or fixed colour.

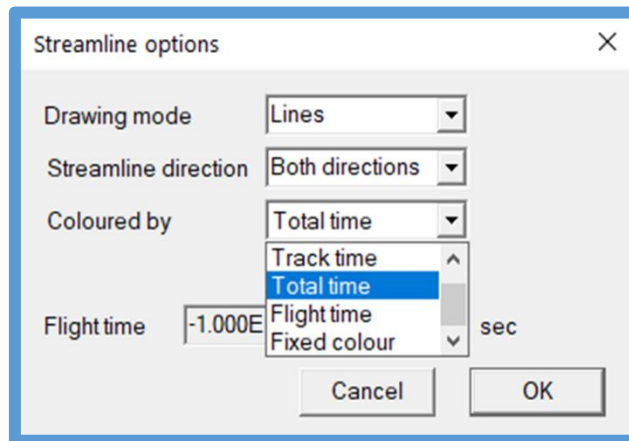

The colour of already-generated streamlines can be altered individually, or by selected groups:

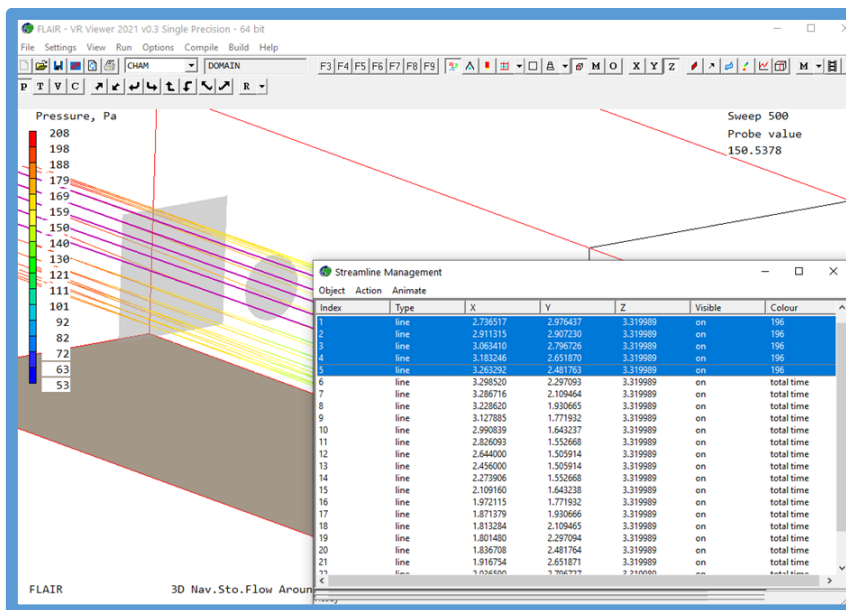

Plotting in Double-cut cells

As mentioned below in the 'Solver' section, the PARSOL cut-cell method has been extended to optionally allow for double-cut cells. The next images show flow past an impervious ring on a very coarse grid.

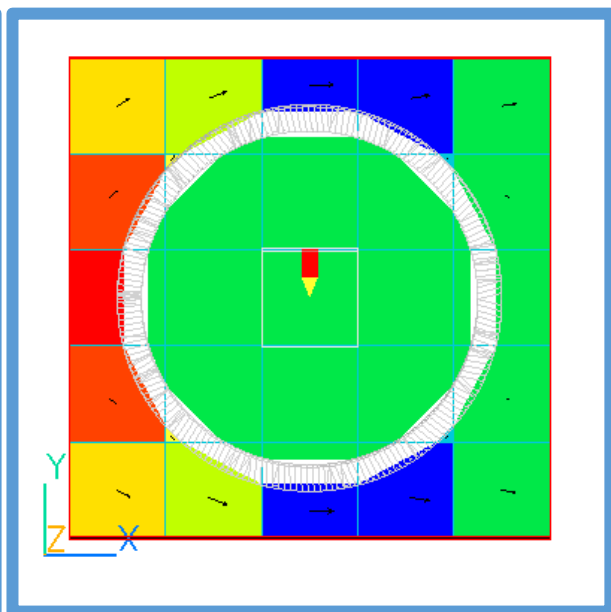
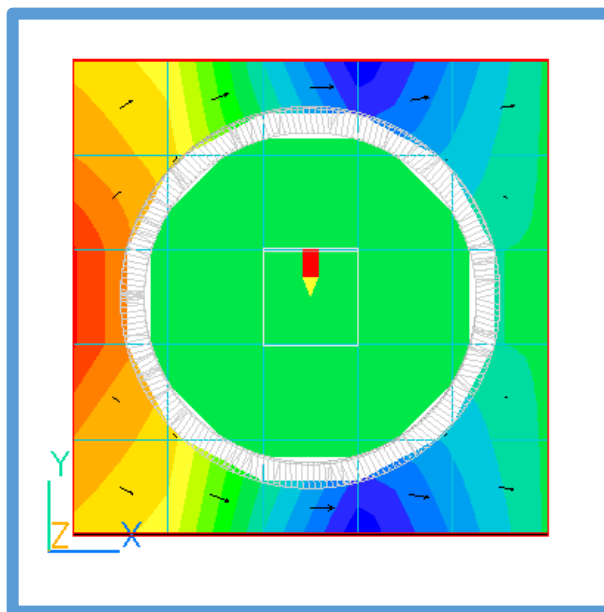
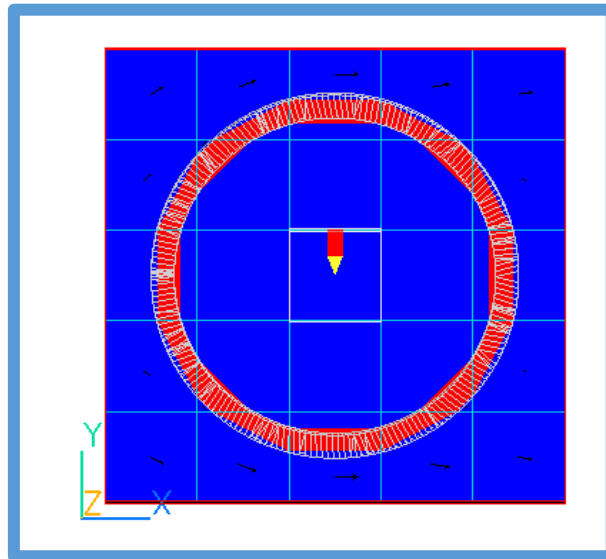

Pressure

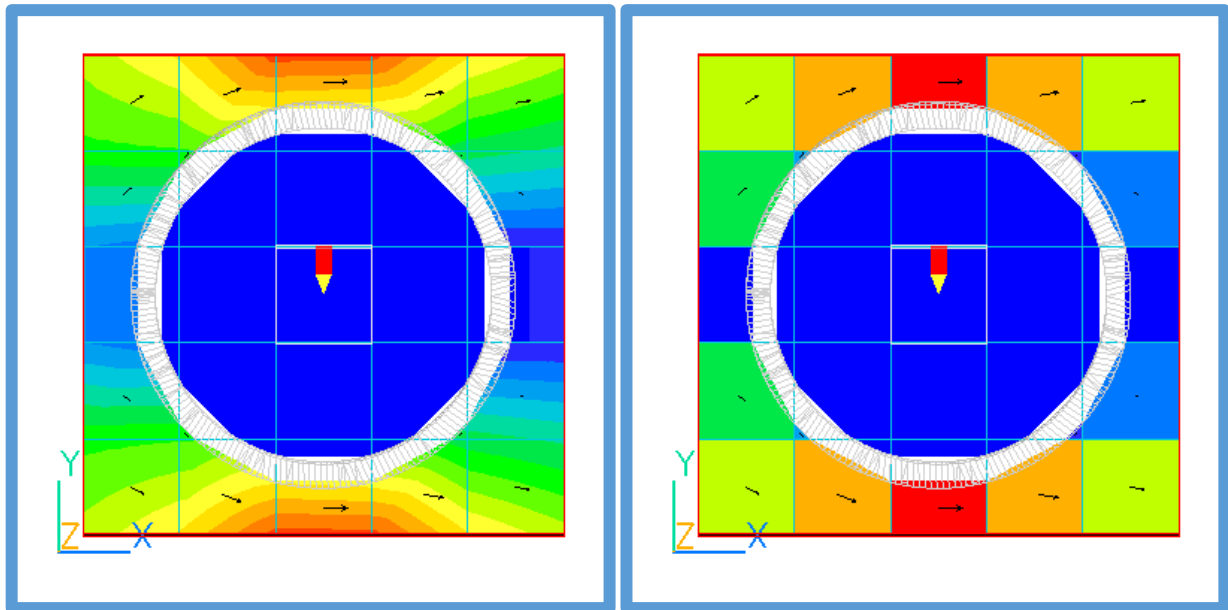

Velocity

Neither Sparsol or Parsol can deal with this situation.

A revised algorithm for obtaining temperatures on the surface of participating solids in the Viewer has been implemented when double-cut detection is active. The normal way in Parsol of obtaining surface temperatures (for Viewer display only) is to average the surrounding values. This leads to a blurring of the contours at a solid-fluid interface:

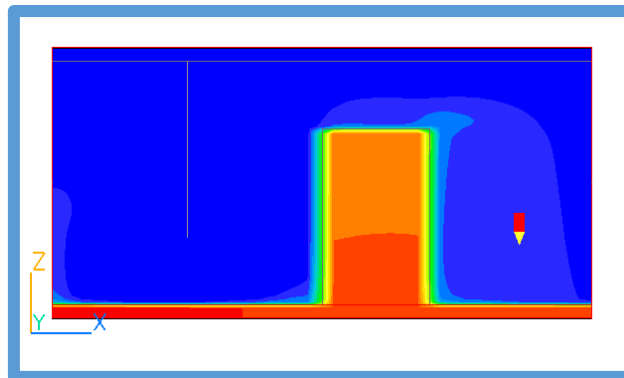

The new algorithm produces an image that is much more like the Sparsol image, showing a clear separation between fluid and solid:

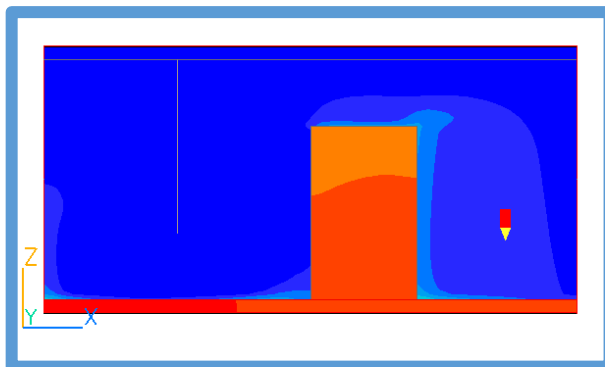

Parsol

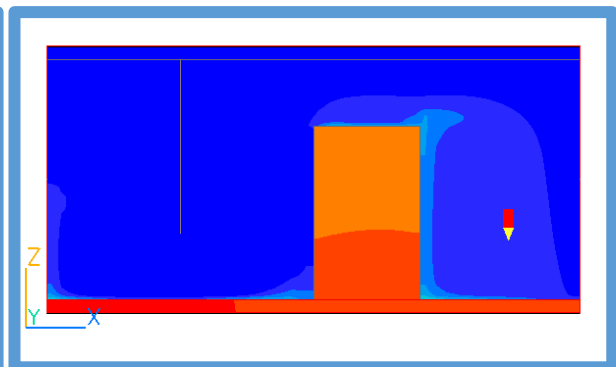

Sparsol

Corrections

Problems with animations with 'Fastread = on' corrected.

Problem with streamline animation for transient cases fixed.

Saving animation as AVI no longer asks for compression type, but defaults to 'Microsoft Video 1'.

Corrections to saving animations from macros to enable an animation to be saved with no user intervention. In this mode, a macro can only contain a single animation.

Solver - Earth

Double-cut cells for Parsol

The detection of double-cut cells for Parsol has been improved. The treatment available in PHOENICS 2020 was far from complete which is why it was not made the default. The current treatment is much improved, but is still not robust enough to be the default.

The method is activated by selecting 'Parsol' on the Grid Mesh Settings dialog and then 'Double-cut detection' on the Settings dialog.

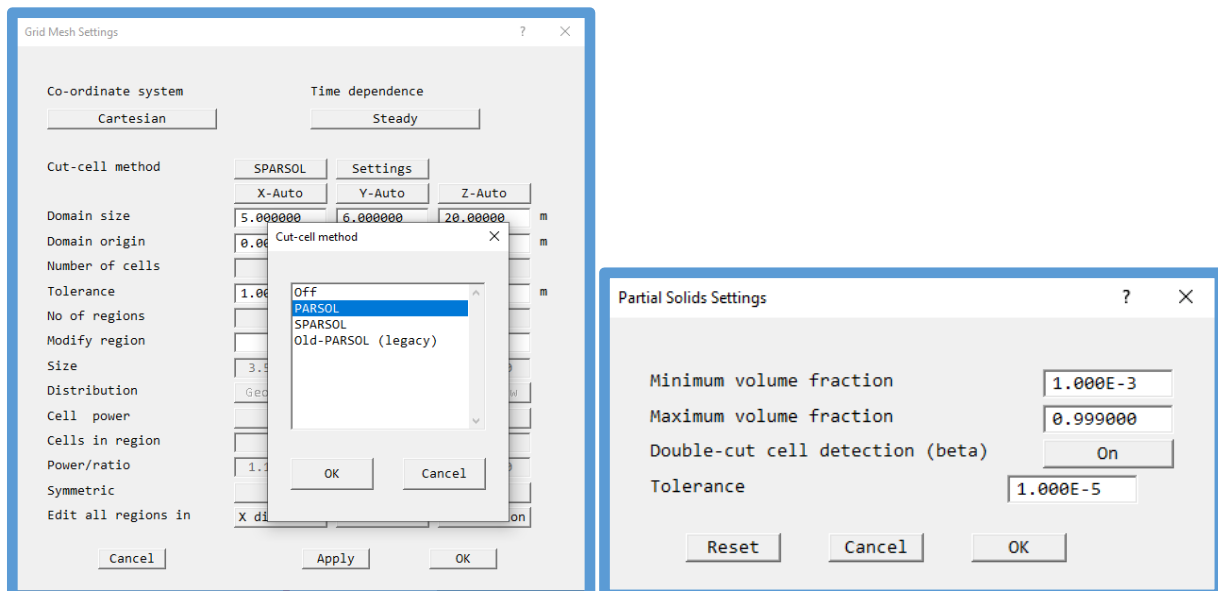

By extending the Parsol treatment to double-cut cells, we allow for a fluid sub-cell on either side of a thin solid, or two solid sub-cells on either side of a thin channel. This creates a locally-unstructured grid, which can be solved using the new solvers introduced for PHOENICS 2019.

The activation of double-cut detection will switch any default solvers to use the AMG solver for pressure and energy and the Conjugate-Residuals-Gradient (CGRS) solver for all other variables.

Limitations

The present treatment of double cut cells has the following limitations:

- Does not run parallel.
- Does not distinguish the two parts of a cut cell when setting a source that should only affect one side.
- Does not activate the full IMMERSOL boundary conditions on either side.

Thinplt

The solar heat load has been added to heat balance to obtain the surface temperatures of the THINPLT object. This has been done for the temperature and enthalpy treatments of the energy equation, with and without IMMERSOL and P1T3 radiation models. The thermal capacity effect has been added for transient cases.

Parallel

File Handling on Startup

The way the facetdat file and phida file for restarts is sent to the slave processors has been changed. Previously, the master node would open the file and send to each of the slaves the parts of the file relevant to each processor. This reading and sending was in effect done a line at a time. For fine grids, this could take a very long time.

Now, each slave checks to see if it can open a shared copy of the file on the master. If they all can, then each reads the parts relevant to it from the master. There is no transmitting of files. If the slaves cannot 'see' the file on the master, perhaps because they are in a cluster and not in the same PC, the entire file is sent to each processor in a different way to before. The file is read in a single read statement, sent in a single MPI send operation then written with a single write. This process is also immensely faster than before.

The same applies to the BFC grid file XYZDA.

In a similar fashion, any other files required to be on all processors, such as InForm PWLF files or transfer object import files, are also transmitted using the new single-read, single-send, single-write method for speed.

Memory allocation

The size of the main Earth storage array, F, is saved to cham.ini to prevent unnecessary 'stretching' of the array the next time the case is run. If a parallel run was performed directly after a sequential, each slave processor would attempt to allocate the same size array as had been required by the sequential run. For large case with large numbers of processors this could lead to the machine becoming completely unresponsive as it tried to handle the memory requests.

The maximum memory allocated in total by all processors is now limited to 80% of the free memory available at runtime.

Corrections

Error in format of sequential PHI file written in parallel fixed.

Corrections to treatment of ROTOR when rotating objects are user-set.

Flair

Apparent temperature with radiation (TAPR)

This comfort index was set to always use the solved humidity equation (MH2O) to derive the relative humidity. A user-set constant relative humidity can now be set if it is not required to solve for humidity.

Corrections

Problem with piece-wise linear FIRE heat / mass source when more than 8 entries in table fixed.

Add missing Fixed-power heat source for Dutch/Belgian smoke models.

The height for evaluating the ROOM average velocity is trapped to be within the current ROOM object.

Corrections to AEROSOL panel in menu to prevent loss of data between visits.

CVD

Corrections

The RAD_SURF object type was deprecated for PHOENICS 2020 – it has been restored for CVD cases.